

H-Bridge Motor Driver

1 Features

- 4.5V to 40V Operating Supply Voltage Range
- Output Current Capability: 4.5A Peak
- Low $R_{DS(ON)}$ Integrated MOSFET:
 - $R_{DS(on)}$ (HS+LS): 200m Ω
- Separate Logic and Motor Power Supply Pins
- Standard PWM Interface (IN1/IN2)
- Low Power Sleep Mode, Maximum Sleep Current 1 μ A
- Small Package and Footprint
 - 8 pin SOP (With Thermal Pad)
- Protection Features
 - Over Current Protection (OCP)
 - Thermal Shutdown (TSD)
 - Under Voltage Lock-Out (UVLO)
 - MOSFET Shoot-Through Prevention

2 Applications

- Home Appliances
- DC Brush Motors
- Printers
- Industrial Automation
- Sweeping Robot

3 Description

The GD30DR3001 is an H-bridge driver, and is designed to drive one DC brush motor or other inductive loads. The H-bridge is composed of four high voltage N-Channel MOSFETs that can control motors bidirectionally with up to 4.5A peak current. Two logic inputs are provided to control the H-bridge driver, and therefore control the speed and direction of the DC motor with externally applied PWM control signals. Setting both inputs low enters a low power sleep mode.

The GD30DR3001 device features integrated current regulation, based on the analog input VREF and the voltage on the ISEN pin, which is proportional to motor current through an external sense resistor. The ability to limit current to a known level can significantly reduce the system power requirements and bulk capacitance needed to maintain stable voltage, especially for motor startup and stall conditions.

The device internal protection includes undervoltage (UVLO), overcurrent(OCP), and overtemperature(TSD). When the fault condition is removed, the device automatically resumes normal operation.

Device Information¹

PART NUMBER	PACKAGE	BODY SIZE (NOM)
GD30DR3001	EP-SOP (8)	4.90 mm × 6.00 mm

1. For packaging details, see [Package Information](#) section.

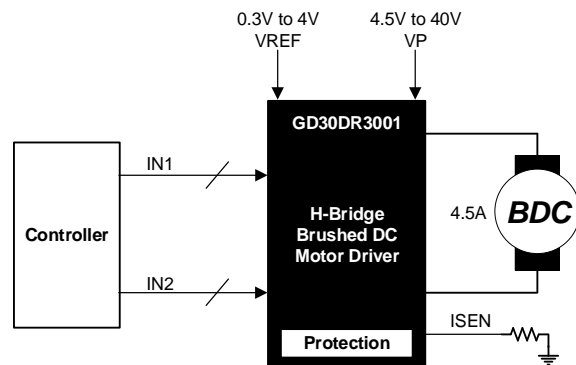

Simplified Application Schematic

Table of Contents

1	Features	1
2	Applications	1
3	Description	1
	Table of Contents	2
4	Device Overview	3
4.1	Pinout and Pin Assignment	3
4.2	Pin Description	3
5	Parameter Information	4
5.1	Absolute Maximum Ratings	4
5.2	Recommended Operation Conditions	4
5.3	Electrical Sensitivity	4
5.4	Thermal Resistance	5
5.5	Electrical Characteristics	5
5.6	Typical Characteristics	7
6	Functional Description	8
6.1	Block Diagram	8
6.2	Operation	8
7	Application Information	11
7.1	Typical Application Circuit	11
7.2	Design Example	11
7.3	Detailed Design Description	11
7.4	Power Dissipation	12
7.5	Typical Application Curves	13
8	Layout Guidelines and Example	15
8.1	Layout Guidelines	15
8.2	Layout Example	15
9	Package Information	16
9.1	Outline Dimensions	16
9.2	Recommended Land Pattern	18
10	Ordering Information	19

4 Device Overview

4.1 Pinout and Pin Assignment

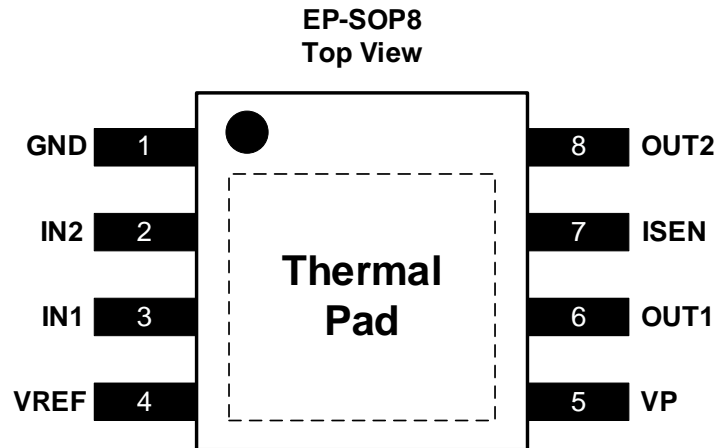

4.2 Pin Description

PIN		PIN TYPE ¹	FUNCTION
NAME	NUM		
GND	1	P	Device logic ground, connect to board ground.
IN2	2	I	Logic input, control signal of H-bridge, internal pulldown. See Table 1 .
IN1	3	I	Logic input, control signal of H-bridge, internal pulldown. See Table 1 .
VREF	4	P	Analog reference voltage for current regulation, apply a voltage between 0.3V to 4V. For information on current regulation, see the Current Regulation section.
VP	5	P	Power supply, connect a 0.1uF bypass capacitor to ground, as well as sufficient bulk capacitance, rated for the VP voltage.
OUT1	6	O	H-bridge output, connect to the DC motor or other inductive load.
ISEN	7	P	Current path to ground, connect a sense resistor to ground to set the current regulation or directly to ground when not using regulation.
OUT2	8	O	H-bridge output, connect to the DC motor or other inductive load.
Thermal pad	Thermal pad	P	Power ground, connect to board ground, use large ground plane for good thermal dissipation, and multiple nearby vias connecting those planes, see Layout Guidelines and Example.

1. I = input, O = output, P = power, G = ground.

5 Parameter Information

5.1 Absolute Maximum Ratings

Exceeding the operating temperature range (unless otherwise noted)^{1,2}

SYMBOL	PARAMETER	MIN	MAX	UNIT
VP	Motor power supply voltage	-0.3	45	V
VREF	Reference voltage	-0.3	6	V
V _{INx}	Control input pin voltage	-0.3	6	V
V _{OUTx}	H-bridge output drive	-1.0	VP + 0.7	V
V _{ISEN}	Current path to ground	-0.7	1	V
I _{LIM}	Internal current limit	0	6	A
T _J	Operating junction temperature	-40	150	°C
T _{stg}	Storage temperature	-65	150	°C

1. Stresses beyond those listed under Absolute Maximum Ratings may cause permanent damage to the device. These are stress ratings only, which do not imply functional operation of the device at these or any other conditions beyond those indicated under Recommended Operating Conditions. Exposure to absolute-maximum-rated conditions for extended periods may affect device reliability.

2. All voltage values are with respect to network ground terminal.

5.2 Recommended Operation Conditions

SYMBOL ^{1,3}	PARAMETER	MIN	TYP	MAX	UNIT
VP	Motor power supply voltage	4.5		40	V
VREF	Reference voltage	0.3		4	V
V _{INx}	Control input pin voltage	0		5.5	V
I _{OUTx}	Continuous motor drive output current	0		3	A
I _{PEAK}	Peak output current ²	0		4.5	A
f _{pwm}	Externally applied PWM frequency	0		100	kHz
V _{ISEN}	Current path to ground	-0.7		1	V
T _A	Operating ambient temperature ²	-40		125	°C

1. The device is not guaranteed to function outside of its operating conditions.

2. Power dissipation and thermal limits must be observed.

3. [Application Information](#) section for further information.

5.3 Electrical Sensitivity

SYMBOL	CONDITIONS	VALUE	UNIT
V _{ESD(HBM)}	Human-body model (HBM), ANSI/ESDA/JEDEC JS-001-2017 ¹	±6000	V
V _{ESD(CDM)}	Charge-device model (CDM), ANSI/ESDA/JEDEC JS-002-2022 ²	±2000	V

1. JEDEC document JEP155 states that 500-V HBM allows safe manufacturing with a standard ESD control process.

2. JEDEC document JEP157 states that 250-V CDM allows safe manufacturing with a standard ESD control process.

5.4 Thermal Resistance

SYMBOL ¹	CONDITIONS	PACKAGE	VALUE	UNIT
Θ_{JA}	Natural convection, 2S2P PCB	EP-SOP8	39.41	°C/W
Θ_{JB}	Cold plate, 2S2P PCB	EP-SOP8	12.83	°C/W
Θ_{JC}	Cold plate, 2S2P PCB	EP-SOP8	26.81	°C/W
Ψ_{JB}	Natural convection, 2S2P PCB	EP-SOP8	12.45	°C/W
Ψ_{JT}	Natural convection, 2S2P PCB	EP-SOP8	2.65	°C/W

1. Thermal characteristics are based on simulation, and meet JEDEC document JESD51-7.

5.5 Electrical Characteristics

$T_A = 25^\circ\text{C}$ (unless otherwise noted).

SYMBOL	PARAMETER	CONDITIONS	MIN	TYP	MAX	UNIT
POWER SUPPLY(VP)						
VP	VP operating voltage		4.5		40	V
I _{VP}	VP operating supply current	VP = 24 V		2	4	mA
I _{VPQ}	VP standby mode current	VP = 24 V			1	μA
t _{WAKE}	Turn-on time	VP > V _{UVLO} , IN1 or IN2 high		40	50	μs
t _{SLEEP}	Turn-off delay time	IN1=IN2=0		1		ms
LOGIC-LEVEL INPUTS(IN1, IN2)						
V _{IL}	Input low voltage				0.8	V
V _{IH}	Input high voltage		1.5			V
V _{HYS}	Input logic hysteresis			500		mV
I _{IL}	Input low current	V _{INx} = 0	-1		1	μA
I _{IH}	Input high current	V _{INx} = 3.3V		30	50	μA
R _{PD}	Pulldown resistance			100		kΩ
t _{PD}	Propagation delay	IN1/IN2 transition to OUT1/OUT2 transition		300		ns
MOTOR DRIVER OUTPUTS(OUT1, OUT2)						
R _{DS(ON)_HS}	High side MOSFET R _{DS(ON)}	VP = 24V, I = 1A, T _A = 25°C		100		mΩ
R _{DS(ON)_LS}	Low side MOSFET R _{DS(ON)}	VP = 24V, I = 1A, T _A = 25°C		100		mΩ
V _D	Body diode forward voltage	I _{OUT} = 1A, T _A = 25°C		0.8	1	V
t _{DT}	Output drive dead time			200		ns
t _{RISE}	Output rise time	OUTx rising from 10% to 90%		170		ns
t _{FALL}	Output fall time	OUTx falling from 10% to 90%		170		ns
CURRENT REGULATION(VREF, ISEN)						
A _v	ISEN gain	VREF = 2.5V		10		V/V
t _{OFF}	Fixed PWM off-time			25		μs
t _{BLANK}	PWM blanking time			2		μs

Electrical Characteristics(continued)

T_A = 25°C (unless otherwise noted).

SYMBOL	PARAMETER	CONDITIONS	MIN	TYP	MAX	UNIT
PROTECTION CIRCUITS						
V _{UVLO}	VP undervoltage lockout	Supply falling	4.0	4.1	4.2	V
V _{UVLO_HYS}	VP undervoltage hysteresis	Rising to falling threshold		150		mV
t _{UVLO}	VP undervoltage deglitch time			10		μs
I _{OCP}	Over current protection		6.0	7.0		A
t _{OCP}	Over current deglitch time			1.5		μs
t _{RETRY}	OCP retry time			3		ms
T _{TSD}	Thermal shutdown temperature			160		°C
T _{HYS}	Thermal shutdown hysteresis			35		°C

5.6 Typical Characteristics

T_A = 25°C, unless otherwise noted.

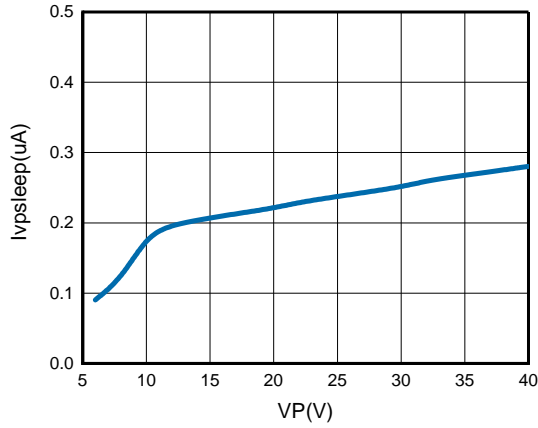

Figure 1. Sleep Current vs. Input Voltage

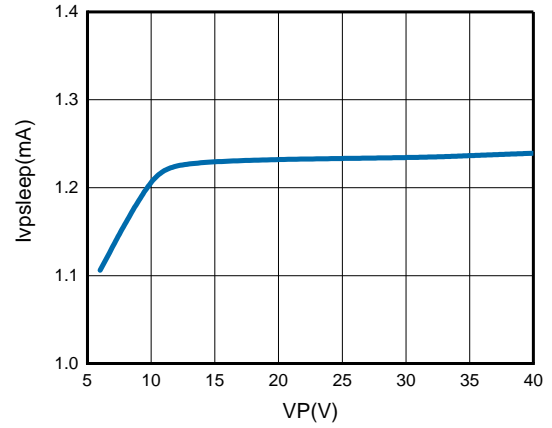

Figure 2. Active Current vs. Input Voltage

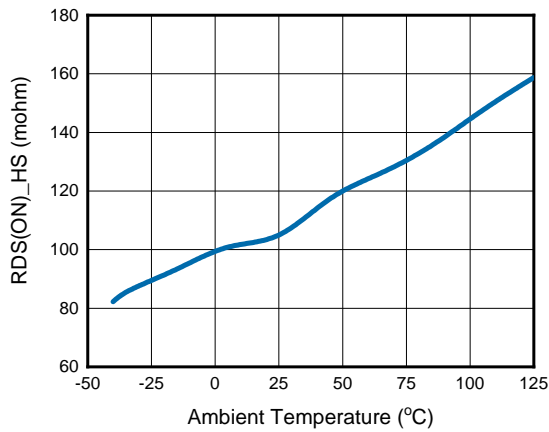

Figure 3. High-Side RDS(ON) vs. Temperature

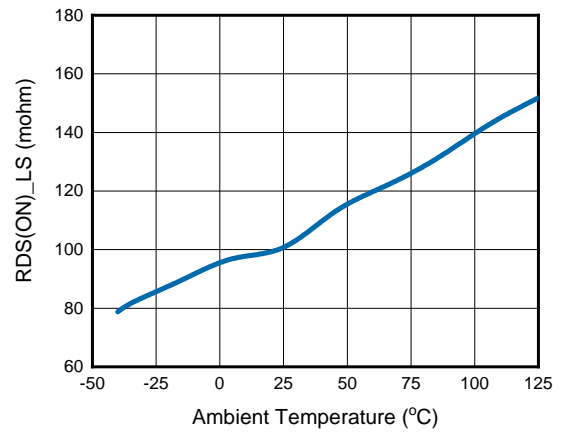

Figure 4. Sleep Current vs. Temperature

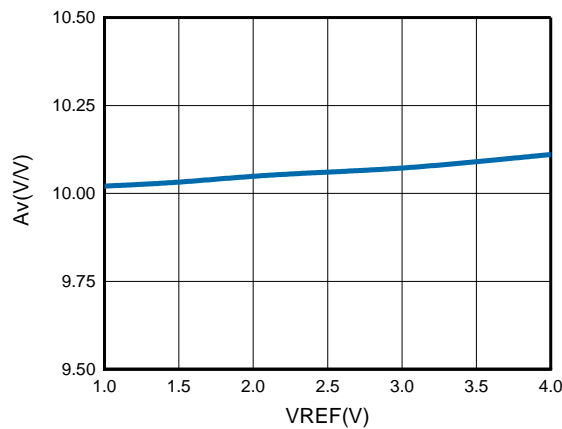

Figure 5. AV vs. VREF

6 Functional Description

6.1 Block Diagram

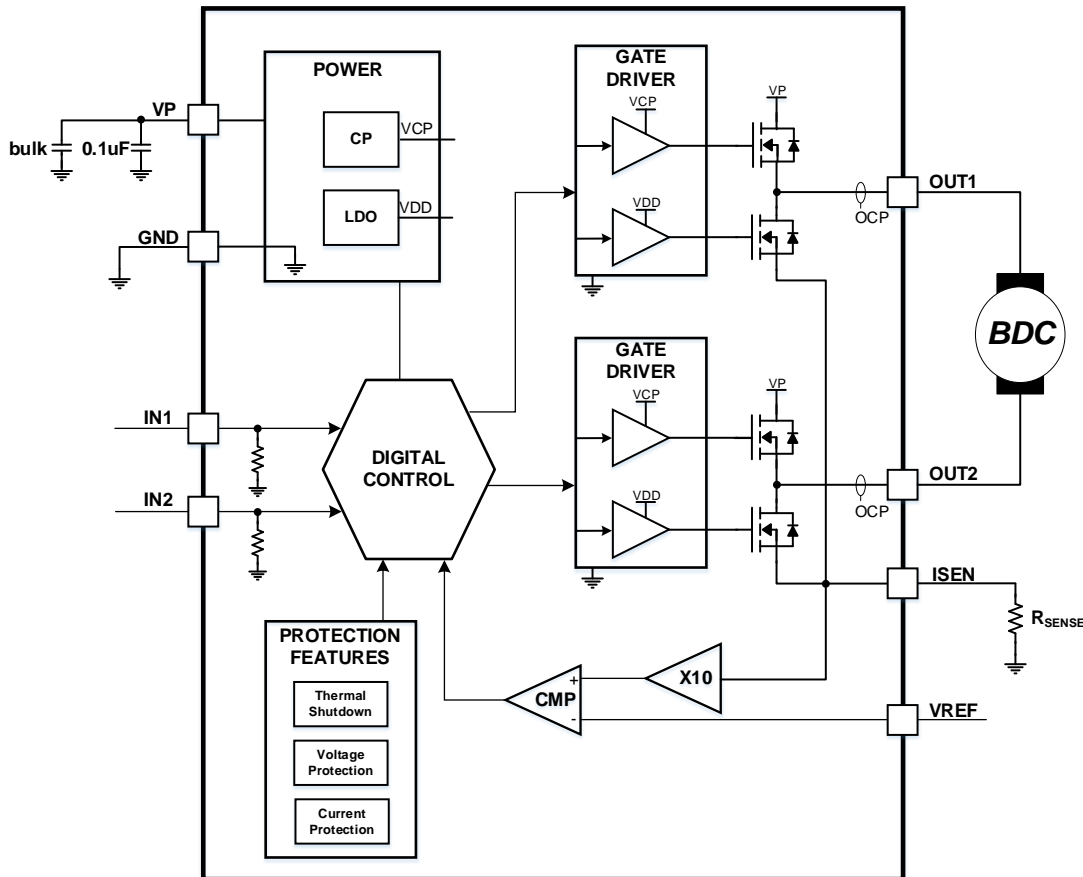

Figure 6. GD30DR3001 Functional Block Diagram

6.2 Operation

The GD30DR3001 serves as an H-bridge driver capable of powering a single DC motor or other devices, such as solenoids. It regulates its outputs through a PWM interface (IN1/IN2) up to 100kHz. When both logic inputs are low for a 1ms period, the device will be set into standby mode and consume less power. Protection features such as OCP, TSD and UVLO are implemented to prevent the device and system from fault and damage.

6.2.1 PWM Mode

In GD30DR3001, the device operates in PWM mode. H-bridge in PWM mode supports four output states: coast (Hi-Z), forward, reverse and brake. They are controlled by IN1/IN2 according to Table 1. The inputs can be set to static voltage for 100% duty cycle drive, or PWM for variable motor speed. When using PWM, it typically works best to switch between driving and braking.

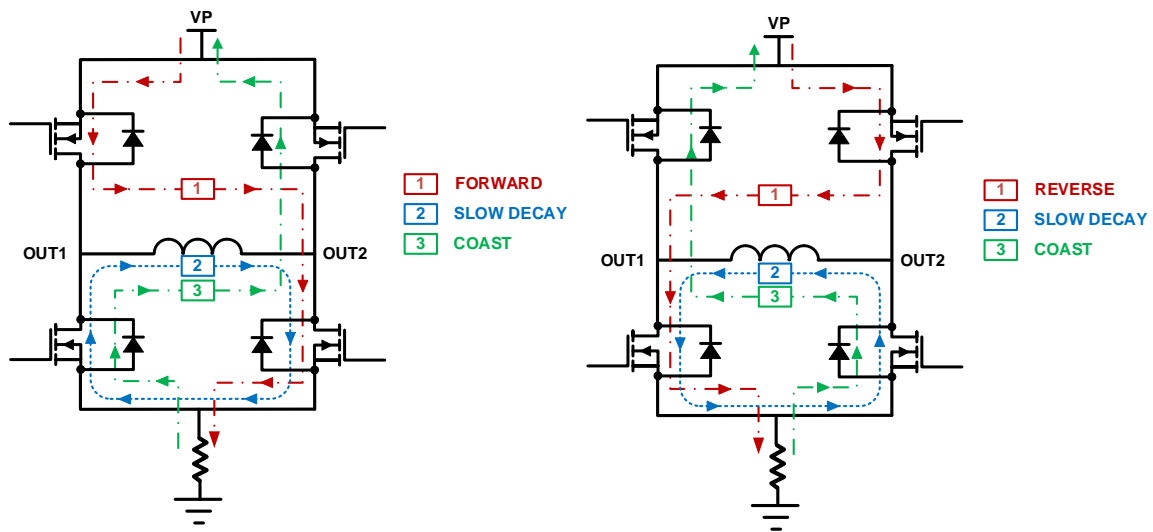

Figure 7. The Driver Outputs and Current Path

Table 1 shows the logic for the GD30DR3001 device.

Table 1. H-Bridge Control

IN1	IN2	OUT1	OUT2	FUNCTION (DC MOTOR)
0	0	Z	Z	Coast
0	1	L	H	Reverse
1	0	H	L	Forward
1	1	L	L	Brake

6.2.2 Dead Time

An internal handshaking scheme is used to prevent shoot-through between the high side and low side MOSFETs. A typical dead time of 200ns is inserted when transitioning between MOSFETs in each half-bridge.

6.2.3 Current Regulation

The output current is regulated at a limit set by an analog input VREF and the resistor RISEN connected from ISEN to ground, according to the equation:

$$I_{TRIP} = \frac{VREF(V)}{A_V \times R_{ISEN}(\Omega)} = \frac{VREF(V)}{10 \times R_{ISEN}(\Omega)} (A) \tag{1}$$

For example, if VREF=3.3V and RISEN=0.2Ω, the GD30DR3001 will limit motor current limit to 1.65A no matter how much load torque is applied.

Usually ITRIP is set above the normal motor operating current, and high enough to achieve adequate spin-up time, and low enough to constrain current to a desired level.

If ISEN is connected to ground directly, the current regulation function is disabled. VREF should still be applied to a value which could provide high noise margin. The output current could go up to 6A for a few hundred millisecond. Over current protection and over temperature protection may be triggered to protect the IC and system.

6.2.4 Mixed current decay

When current regulation is triggered, IC will enter a fixed time PWM off cycle to re-circulate the current. By default, the device enforces slow current decay by enabling both low-side MOSFETs for the fixed off time (t_{OFF} , 25 μ s typical).

A mixed current decay mode is implemented as an option only in GD30DR3001. In this mode, when current regulation is triggered, the driver outputs are switched to opposite polarity (High to Low, or Low to High) for the first half t_{OFF} . In the latter half of t_{OFF} , the driver is switched back to slow-decay mode. Mixed current decay are explained in Figure 8.

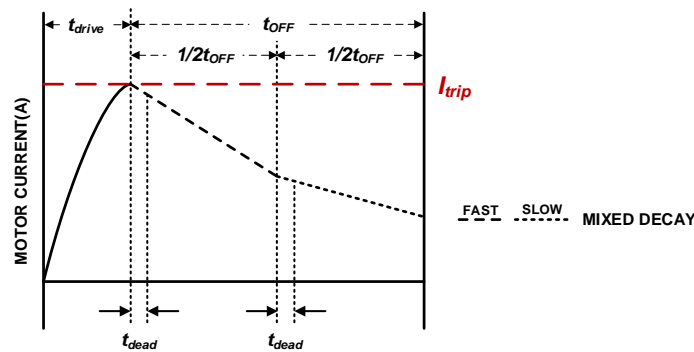

Figure 8. Mixed Current Decay

6.2.5 Protection Circuits

6.2.5.1 Power Supply Undervoltage Lockout(UVLO)

At any time if the voltage on the power supply V_P falls below the UVLO threshold, all the internal MOSFETs in the H-bridge will be disabled. Normal operation will resume when V_P rises above UVLO threshold.

6.2.5.2 Overcurrent Protection (OCP)

The individual currents go through the MOSFETs (high-side and low-side) are monitored cycle by cycle. In case any current is over the over-current limit (6A typical), all the MOSFETs are disabled and the internal power supply will be shutdown. The recycle of the PWM control will be retried after a delay time of 3ms and normal operation will be resumed if the OCP events are cleared.

6.2.5.3 Thermal Shutdown (TSD)

If the die temperature exceeds the trip point of the thermal shutdown limit (T_{TSD} , typical 150°C), all the MOSFETs are disabled, the internal power supplies are shut down. Normal operation starts again when the temperature falls below the hysteresis and the over temperature condition clears.

Table 2. Fault Conditions Summary

FAULT	CONDITION	H-BRIDGE	INTERNAL CIRCUIT	RECOVERY
VP undervoltage(UVLO)	$V_P < 4.2V$	Disabled	Disabled	$V_P > 4.2V$
Overcurrent(OCP)	$I_{OUT} > 6A$ (MIN)	Disabled	Operating	t_{OCP_RST}
Thermal Shutdown(TSD)	$T_J > 150^\circ C$ (MIN)	Disabled	Operating	$T_J < T_{OTSD} - T_{HYS}$

7 Application Information

The GD30DR3001 is typically used to drive one brushed DC motor or other inductive loads.

7.1 Typical Application Circuit

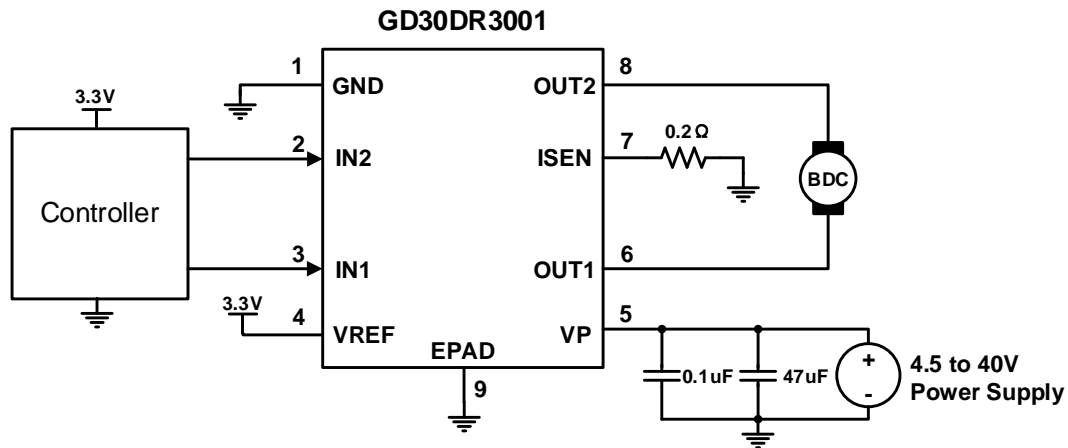

Figure 9. Schematic of GD30DR3001 Application

7.2 Design Example

For this design example, use the parameters in [Table 3](#).

Table 3. Design Parameters

DESIGN PARAMETER	REFERENCE	EXAMPLE VALUE
Motor voltage	VP	24 V
Motor RMS current	I _{RMS}	0.8 A
Motor startup current	I _{START}	2 A
Motor current trip point	I _{TRIP}	1.65 A
VREF voltage	V _{REF}	3.3 V
Sense resistance	R _{SENS}	0.2 Ω
PWM frequency	f _{PWM}	2 KHz

7.3 Detailed Design Description

7.3.1 Motor Voltage

The motor voltage to use will depend on the ratings of the motor selected and the desired RPM. A higher voltage spins a brushed DC motor faster with the same PWM duty cycle applied to the power MOSFETs. A higher voltage also increases the rate of current change through the inductive motor windings.

7.3.2 Low Power Mode

When entering sleep mode, GD recommends keeping all input pins low level to minimize system power consumption.

7.3.3 Sense Resistor

To ensure optimal performance, it is important for the sense resistor to be:

- Surface-mount
- Rated power meets the requirements
- Low Inductance
- Placed as close as to the motor driver pin

The power dissipated by the sense resistor can be calculated using $(I_{RMS})^2 \times R$. For example, if peak motor current is 2A, RMS motor current is 1A, and a 0.2Ω sense resistor is used, the resistor dissipates $1A^2 \times 0.2\Omega = 0.2W$. The power rapidly increases with higher current levels.

Resistors generally have a rated power within a specific range of ambient temperature and a reduced power curve at high ambient temperatures. When the PCB is shared with other components generating heat, the system designer should increase the margin. It is always best to measure the actual sense resistor temperature in a final system.

Power resistors are larger and more expensive than standard resistors, and it is common to use multiple standard resistors in parallel between the sense node and ground to distribute the current and heat dissipation.

7.4 Power Dissipation

Power dissipation in the GD30DR3001 is dominated by the power dissipated in the output FET resistance, or $R_{DS(ON)}$. There is additional power due to PWM switching losses, which are dependent on PWM frequency, rise and fall time, and VP supply voltages. These switching losses are typically on the order of 10% to 30% of DC power dissipation.

The power dissipation of the GD30DR3001 device is on function of RMS motor current and FET ON-resistance of each output.

$$P_D \approx I_{RMS}^2 \times (R_{HS_DS(ON)} + R_{LS_DS(ON)}) \quad (2)$$

where

- P_D is the device power dissipation
- $R_{HS_DS(ON)}$ is the resistance of the high-side FET
- $R_{LS_DS(ON)}$ is the resistance of the low-side FET
- I_{RMS} is the RMS or DC output current being supplied to the load

$R_{DS(ON)}$ increases with temperature, so as the device heats, the power dissipation increases. This must be taken into consideration when sizing the heatsink.

7.5 Typical Application Curves

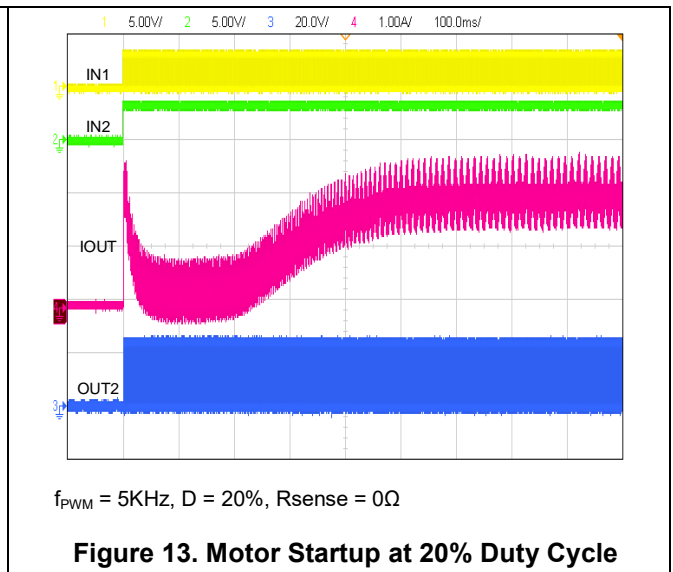
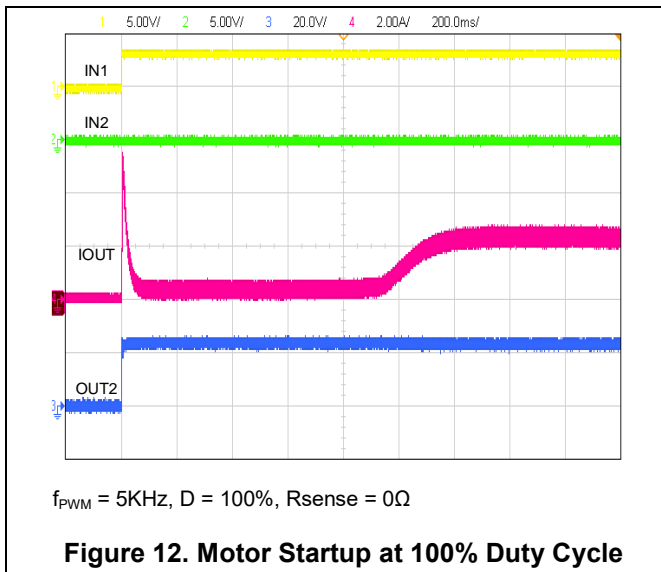
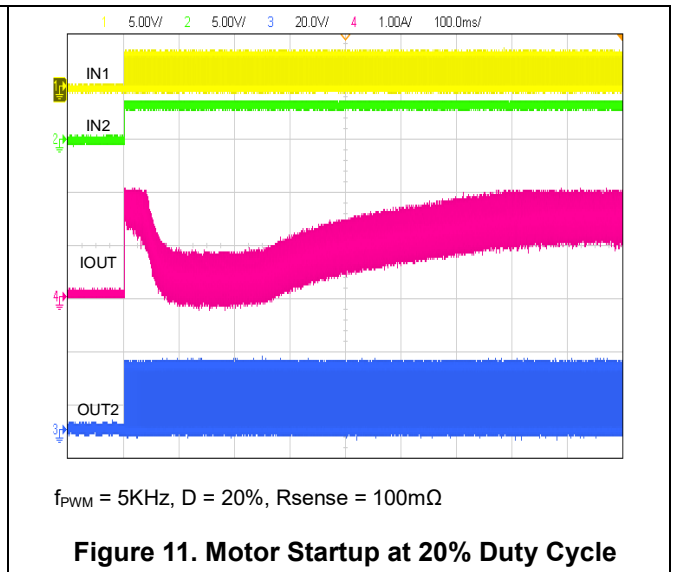
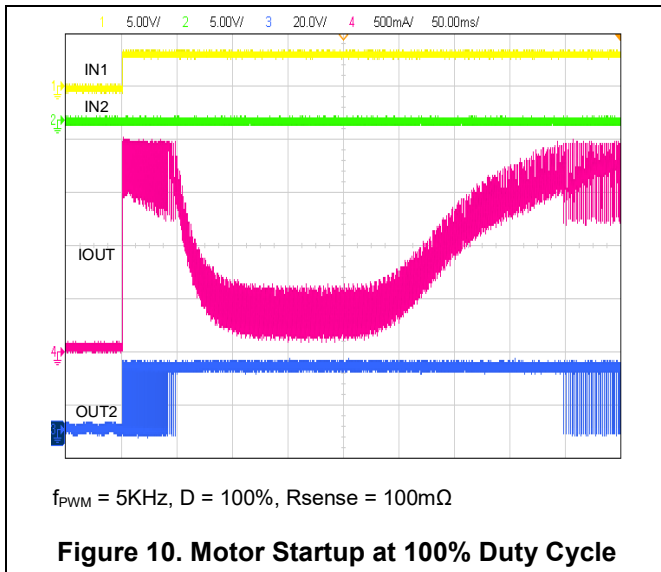

Typical Application Curves (continued)

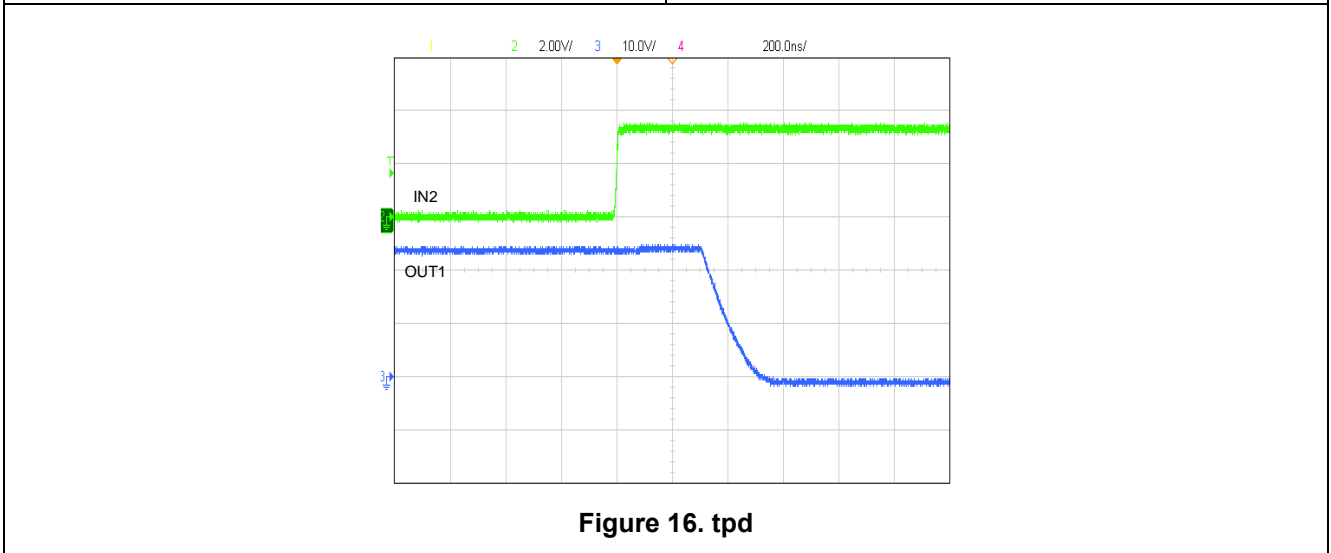
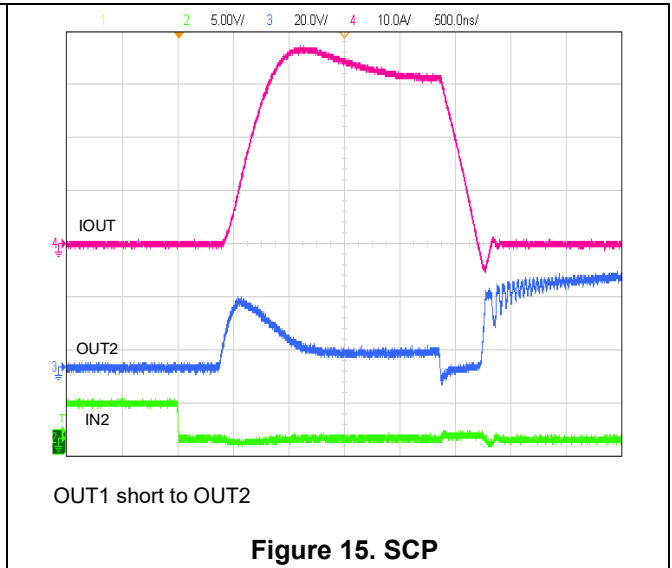
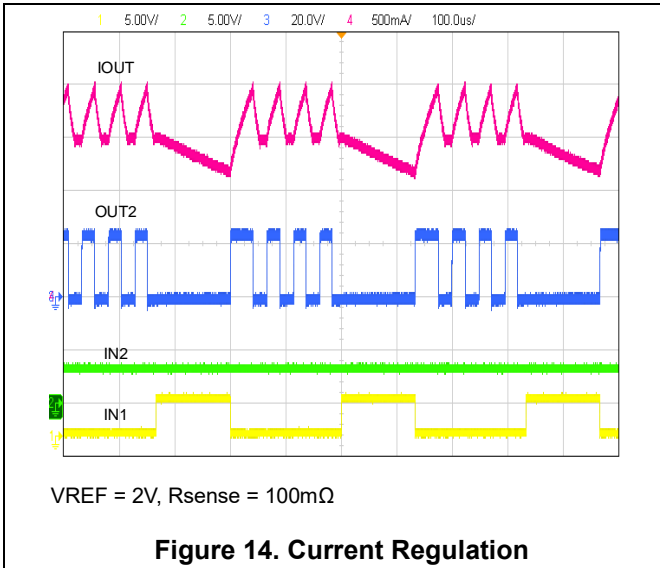

8 Layout Guidelines and Example

8.1 Layout Guidelines

Low ESR ceramic capacitors should be utilized for the VP to GND bypass capacitors. 0.1uF X5R or X7R types are recommended. These capacitors should be placed as close to the VP pin as possible with a thick trace or ground plane connection to the device GND pin.

In addition, bulk capacitor is required on the VP pin. This bulk capacitor can be ceramic or electrolytic type, but should also be placed as close as possible to the VP pin to minimize the loop inductance.

The high-current device outputs should use wide metal trace, and numerous vias should be used when connecting PCB layers.

8.2 Layout Example

Recommended layout and placement is shown in the following diagram.

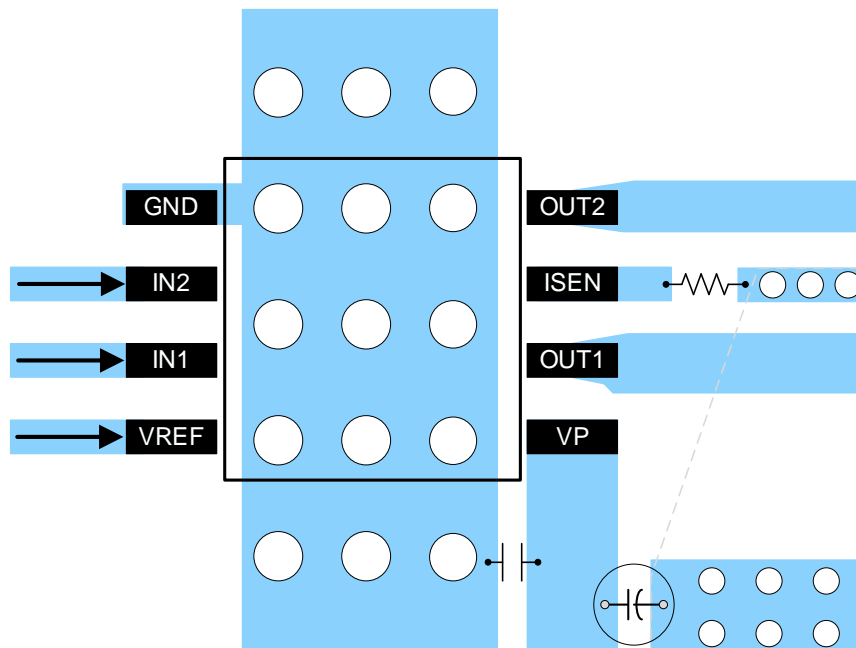
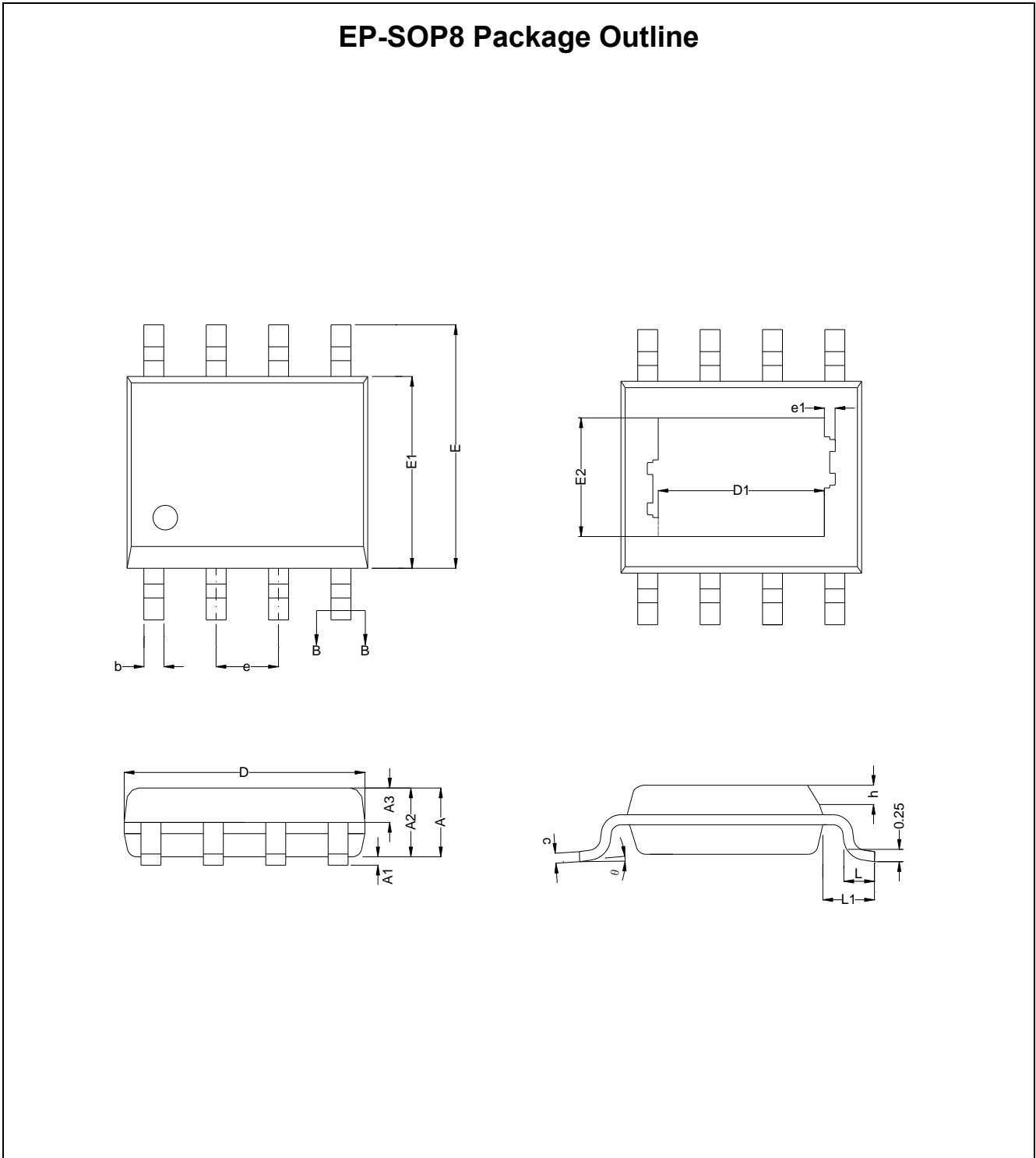

Figure 17. Simplified Layout Example

9 Package Information

9.1 Outline Dimensions



NOTES:

1. All dimensions are in millimeters.
2. Package dimensions does not include mold flash, protrusions, or gate burrs.
3. Refer to the [Table 4 EP-SOP8 dimensions\(mm\)](#).

Table 4. EP-SOP8 dimensions(mm)

SYMBOL	MIN	TYP	MAX
A			1.65
A1	0.05		0.15
A2		1.30	
A3	0.60	0.65	0.70
b	0.39		0.47
c	0.20		0.24
D	4.80	4.90	5.00
D1		3.10	
E	5.80	6.00	6.20
E1	3.80	3.90	4.00
E2		2.21	
e		1.27	
e1		0.10	
L	0.50	0.60	0.80
L1		1.05	
h	0.25		0.50
θ	0°		8°

9.2 Recommended Land Pattern

EP-SOP8 Land Pattern Example

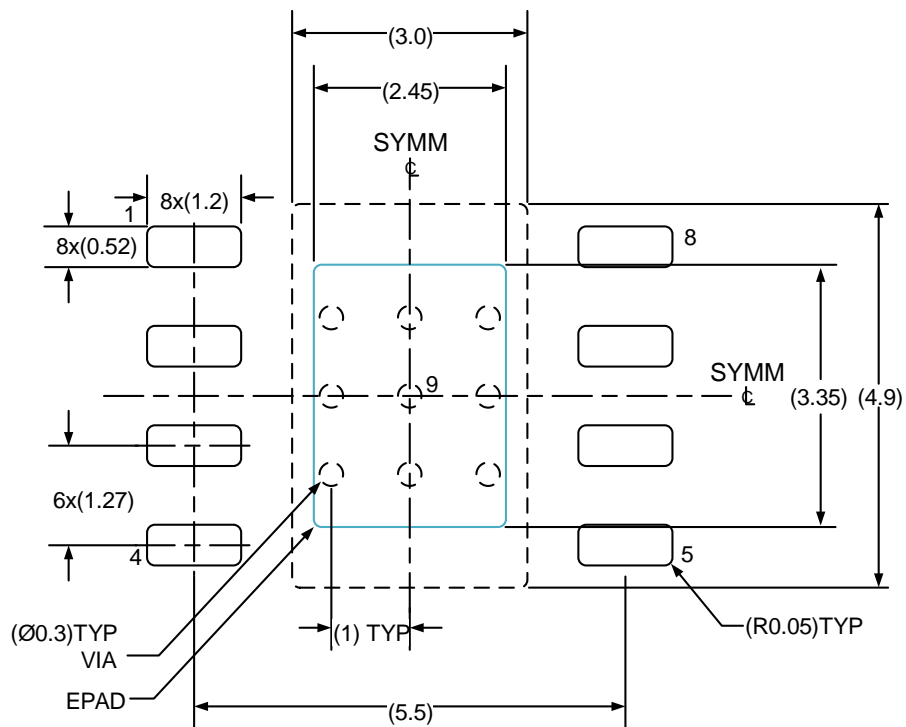

NOTES: (continued)

1. Refer to the IPC-7351 can also help you complete the designs.
2. Exposed metal shown.
3. Drawing is 10X scale.



10 Ordering Information

Ordering Code	Package Type	ECO Plan	Packing Type	MOQ	OP Temp(°C)
GD30DR3001WGTR-K	EP-SOP8	Green	Tape & Reel	3000	-40°C to +125°C

Important Notice

This document is the property of GigaDevice Semiconductor Inc. and its subsidiaries (the "Company"). This document, including any product of the Company described in this document (the "Product"), is owned by the Company according to the laws of the People's Republic of China and other applicable laws. The Company reserves all rights under such laws and no Intellectual Property Rights are transferred (either wholly or partially) or licensed by the Company (either expressly or impliedly) herein. The names and brands of third party referred thereto (if any) are the property of their respective owner and referred to for identification purposes only.

The Company makes no representations or warranties of any kind, express or implied, with regard to the merchantability and the fitness for a particular purpose of the Product, nor does the Company assume any liability arising out of the application or use of any Product described in this document. Any information provided in this document is provided only for reference purposes. It is the sole responsibility of the user of this document to determine whether the Product is suitable and fit for its applications and products planned, and properly design, program, and test the functionality and safety of its applications and products planned using the Product. Unless otherwise expressly specified in the datasheet of the Product, the Product is designed, developed, and/or manufactured for ordinary business, industrial, personal, and/or household applications only, and the Product is not designed or intended for use in (i) safety critical applications such as weapons systems, nuclear facilities, atomic energy controller, combustion controller, aeronautic or aerospace applications, traffic signal instruments, pollution control or hazardous substance management; (ii) life-support systems, other medical equipment or systems (including life support equipment and surgical implants); (iii) automotive applications or environments, including but not limited to applications for active and passive safety of automobiles (regardless of front market or aftermarket), for example, EPS, braking, ADAS (camera/fusion), EMS, TCU, BMS, BSG, TPMS, Airbag, Suspension, DMS, ICMS, Domain, ESC, DCDC, e-clutch, advanced-lighting, etc.. Automobile herein means a vehicle propelled by a self-contained motor, engine or the like, such as, without limitation, cars, trucks, motorcycles, electric cars, and other transportation devices; and/or (iv) other uses where the failure of the device or the Product can reasonably be expected to result in personal injury, death, or severe property or environmental damage (collectively "Unintended Uses"). Customers shall take any and all actions to ensure the Product meets the applicable laws and regulations. The Company is not liable for, in whole or in part, and customers shall hereby release the Company as well as its suppliers and/or distributors from, any claim, damage, or other liability arising from or related to all Unintended Uses of the Product. Customers shall indemnify and hold the Company, and its officers, employees, subsidiaries, affiliates as well as its suppliers and/or distributors harmless from and against all claims, costs, damages, and other liabilities, including claims for personal injury or death, arising from or related to any Unintended Uses of the Product.

Information in this document is provided solely in connection with the Product. The Company reserves the right to make changes, corrections, modifications or improvements to this document and the Product described herein at any time without notice. The Company shall have no responsibility whatsoever for conflicts or incompatibilities arising from future changes to them. Information in this document supersedes and replaces information previously supplied in any prior versions of this document.

© 2023 GigaDevice – All rights reserved