

Dual H-Bridge Stepper Motor Driver

1 Features

- Dual H-Bridge Current Control Motor Driver
 - One Stepper Motor
 - Low MOSFET ON-Resistance:
 - HS + LS 1.0Ω(Typical, 25°C)
- Output Current Capability (at $V_M = 5V, 25^\circ C$)
 - eTSSOP Package:
 - 1.0A RMS, 1.2A Peak per H-Bridge
 - QFN Package:
 - 0.9A RMS, 1.2A Peak per H-Bridge
- Wide Power Supply Voltage: 2.5V to 10.8V
- Integrated Current Regulation
- Easy Pulse-Width-Modulation (PWM) Interface
- Protection Features
 - VM Undervoltage Lockout (UVLO)
 - Overcurrent Protection (OCP)
 - Thermal Shutdown (TSD)
 - Fault Indication Pin(nFAULT)

2 Applications

- Point-of-Sale Printers
- Video Security Cameras
- Office Automation Machines
- Gaming Machines
- Robotics
- Battery-Powered Toys

3 Description

The GD30DR3820 provides a dual-bridge steppe motor driver solution for cameras, printers, toys, robotics and other mechatronic applications.

The device has two H-bridge drivers, drive a bipolar stepper motor. The output driver block consists of N-channel power MOSFETs configured as an H-bridge to drive the motor winding. An internal charge pump generates gate drive voltages.

The GD30DR3820 device has two PWM(IN/IN) input interface. Internal shutdown functions with a fault output pin are provided for overcurrent protection, short circuit protection, undervoltage lockout, and overtemperature. In addition, GD30DR3820 also supports low-power sleep mode.

The GD30DR3820 is packaged in a 16-pin eTSSOP and 16-pin QFN package.

Device Information¹

PART NUMBER	PACKAGE	BODY SIZE (NOM)
GD30DR3820	eTSSOP (16)	5.00 mm × 6.40 mm
	QFN (16)	3.00 mm × 3.00 mm

1. For packaging details, see [Package Information](#) section.

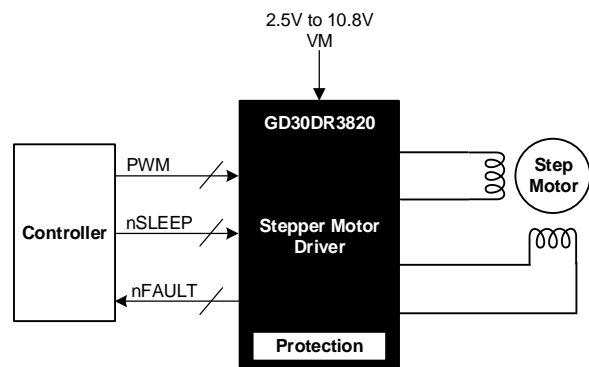

Simplified Application Schematic

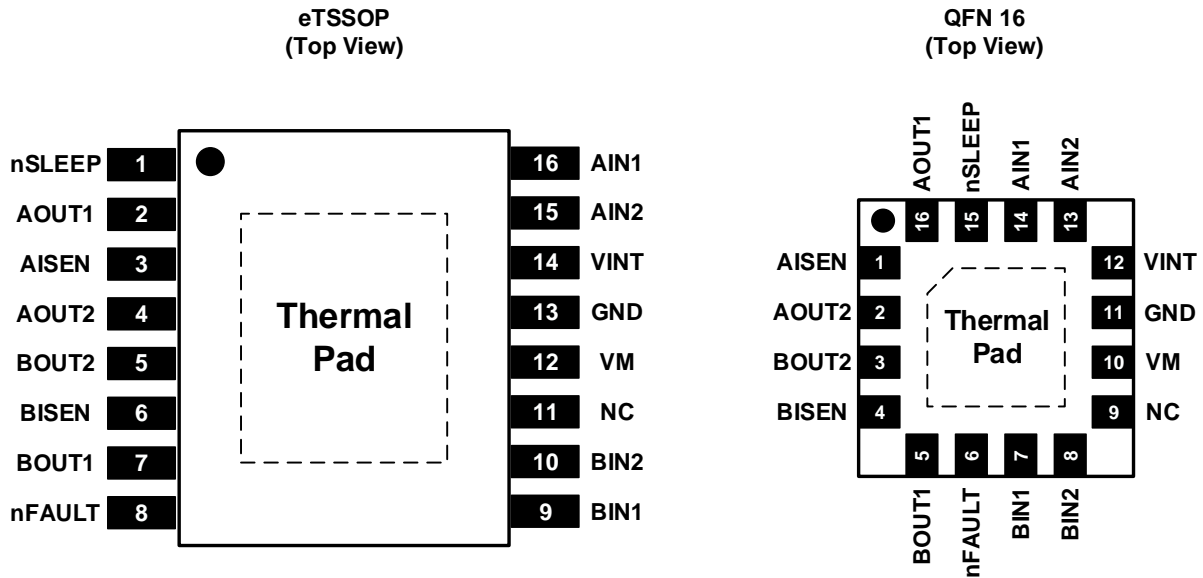

Table of Contents

1	Features	1
2	Applications	1
3	Description	1
	Table of Contents	2
4	Device Overview	3
4.1	Pinout and Pin Assignment	3
4.2	Pin Description	3
5	Parameter Information	5
5.1	Absolute Maximum Ratings	5
5.2	Recommended Operation Conditions	5
5.3	Electrical Sensitivity	5
5.4	Electrical Characteristics	6
6	Functional Description	8
6.1	Block Diagram	8
6.2	Operation	9
6.3	Device Functional Modes	12
7	Application Information	14
7.1	Typical Application Circuit	14
7.2	Design Example	14
7.3	Detailed Design Description	14
7.4	Power Dissipation	15
7.5	Typical Application Curves	16
8	Layout Guidelines and Example	17
8.1	Layout Guidelines	17
8.2	Layout Example	17
9	Package Information	18
9.1	Outline Dimensions	18
9.2	Recommended Land Pattern	22
10	Ordering Information	24

4 Device Overview

4.1 Pinout and Pin Assignment



4.2 Pin Description

PIN NUMBER			PIN TYPE ¹	FUNCTION
NAME	eTSSOP	QFN		
nSLEEP	1	15	I	Sleep mode input. Logic high to enable device; Logic low to enter low-power sleep mode and reset all internal logic; Internal pulldown.
AOUT1	2	16	O	Bridge A output 1. Connect to motor winding A.
AISEN	3	1	I/O	Bridge A ground or Isense. Connect to current sense resistor for bridge A or GND if current control not needed.
AOUT2	4	2	O	Bridge A output 2. Connect to motor winding A.
BOUT2	5	3	O	Bridge B output 2. Connect to motor winding B.
BISEN	6	4	I/O	Bridge B ground or Isense. Connect to current sense resistor for bridge B or GND if current control not needed.
BOUT1	7	5	O	Bridge B output 1. Connect to motor winding B.
nFAULT	8	6	OD	Fault output. Logic low when in fault condition (overtemperature, overcurrent, undervoltage lockout).
BIN1	9	7	I	Bridge B input 1. Controls the state of BOUT1. Internal pulldown.
BIN2	10	8	I	Bridge B input 2. Controls the state of BOUT2. Internal pulldown.
NC	11	9		No connection pin.
VM	12	10	P	Power supply. Connect to motor supply. A 10uF(minimum) ceramic bypass capacitor to GND is recommended.
GND	13	11	P	Device ground. This pin must be connected to the PCB ground.



VINT	14	12	P	Internal regulator. Bypass to GND with a 2.2uF, 6.3V capacitor.
AIN2	15	13	I	Bridge A input 2. Controls the state of AOUT2. Internal pulldown.
AIN1	16	14	I	Bridge A input 1. Controls the state of AOUT1. Internal pulldown.
GND	Thermal	Thermal	P	Power ground, connect to board ground, use large ground plane for good thermal dissipation, and multiple nearby vias connecting those planes.

1. I = input, O = output, I/O= input/output, OD =open drain, P = power.

5 Parameter Information

5.1 Absolute Maximum Ratings

Exceeding the operating temperature range (unless otherwise noted)^{1,2}

SYMBOL	PARAMETER	MIN	MAX	UNIT
VM	Power supply voltage	-0.3	12	V
VINT	Internal regulator	-0.3	3.8	V
	Logic input pin voltage	-0.5	7.0	V
	Peak motor drive output current	Internally limited		A
T _J	Operating junction temperature	-40	150	°C
T _{stg}	Storage temperature	-60	150	°C

1. Stresses beyond those listed under Absolute Maximum Ratings may cause permanent damage to the device. These are stress ratings only, which do not imply functional operation of the device at these or any other conditions beyond those indicated under Recommended Operating Conditions. Exposure to absolute-maximum-rated conditions for extended periods may affect device reliability.

2. All voltage values are with respect to network ground terminal.

5.2 Recommended Operation Conditions

SYMBOL ^{1,2}	PARAMETER	MIN	TYP	MAX	UNIT
VM	Motor power supply voltage ³	2.5		10.8	V
V _{LOGIC}	Logic level input voltage	0		5.5	V
I _{RMS}	Motor RMS current ⁴	eTSSOP16 Package		1.0	A
		QFN16 Package		0.9	A
f _{pwm}	Externally applied PWM frequency	0		200	kHz
T _A	Operating ambient temperature ⁴	-40		85	°C

1. The device is not guaranteed to function outside of its operating conditions.

2. Refer to the [Application Information](#) section for further information.

3. Note that when VM is below 5 V, R_{DS(ON)} increases and maximum output current is reduced.

4. Power dissipation and thermal limits must be observed.

5.3 Electrical Sensitivity

SYMBOL	CONDITIONS	VALUE	UNIT
V _{ESD(HBM)}	Human-body model (HBM), ANSI/ESDA/JEDEC JS-001-2017 ¹	±3000	V
V _{ESD(CDM)}	Charge-device model (CDM), ANSI/ESDA/JEDEC JS-002-2022 ²	±1500	V

1. JEDEC document JEP155 states that 500-V HBM allows safe manufacturing with a standard ESD control process.

2. JEDEC document JEP157 states that 250-V CDM allows safe manufacturing with a standard ESD control process.

5.4 Electrical Characteristics

T_A = 25°C, unless otherwise noted.

SYMBOL	PARAMETER	CONDITIONS	MIN	TYP	MAX	UNIT
POWER SUPPLY (VM, VINT)						
VM	VM operating voltage		2.5		10.8	V
I _{VM}	VM operating supply current	V _M =5V, xINx low, nSLEEP high		0.6	1.0	mA
I _{VMQ}	VM sleep mode supply current	V _M =5V, nSLEEP low		30	95	nA
t _{sleep}	Sleep time	nSLEEP low to sleep mode		10		μs
t _{wake}	Wake-up time	nSLEEP high to output transition		155		μs
t _{on}	Turn-on time	V _M > V _{UVLO} to output transition		25		μs
VINT	Internal regulator voltage	V _M = 5V	3.2	3.5	3.8	V
V _{UVLO}	VM undervoltage lockout voltage	V _M rising			2.5	V
		V _M falling			2.4	V
LOGIC-LEVEL INPUTS (AIN1, AIN2, BIN1, BIN2, nSLEEP)						
V _{IL}	Input low voltage	xINx	0		0.7	V
		nSLEEP	0		0.5	V
V _{EN_FALL}	Input high voltage	xINx	1.8		5.5	V
		nSLEEP	2.3		5.5	V
V _{HYS}	Input logic hysteresis		200	300	500	mV
I _{IL}	Input low current	V _{IN} = 0	-5		5	μA
I _{IH}	Input high current	V _{IN} = 5V			50	μA
R _{PD}	Pulldown resistance			100		KΩ
t _{DEG}	Input deglitch time				600	ns
T _{PROP}	Propagation delay INx to OUTx	V _M = 5V			1.2	μs
CONTROL OUTPUT (nFAULT)						
V _{OL}	Output logic low voltage	I _o = 5mA			0.1	V
I _{OH}	Output logic high leakage	V _o = 3.3V	-1		1	μA
MOTOR DRIVER OUTPUTS(AOUT1, AOUT2, BOUT1, BOUT2)						
R _{DS(ON)}	High-side FET on resistance	V _M = 5V, I _o = 0.2A, T _J = -40°C ¹		400		mΩ
		V _M = 5V, I _o = 0.2A, T _J = 20°C		550		mΩ
		V _M = 5V, I _o = 0.2A, T _J = 85°C ¹		650		mΩ
		V _M = 2.7V, I _o = 0.2A, T _J = -40°C ¹		650		mΩ
		V _M = 2.7V, I _o = 0.2A, T _J = 25°C		800		mΩ
		V _M = 2.7V, I _o = 0.2A, T _J = 85°C ¹		900		mΩ
	Low-side FET on resistance	V _M = 5V, I _o = 0.2A, T _J = -40°C ¹		350		mΩ
		V _M = 5V, I _o = 0.2A, T _J = 20°C		450		mΩ
V _M = 5V, I _o = 0.2A, T _J = 85°C ¹			550		mΩ	
V _M = 2.7V, I _o = 0.2A, T _J = -40°C ¹			650		mΩ	

Electrical Characteristics(continued)

$T_A = 25^\circ\text{C}$ (unless otherwise noted).

SYMBOL	PARAMETER	CONDITIONS	MIN	TYP	MAX	UNIT
R _{DSON}	Low-side FET on resistance	$V_M = 2.7\text{V}, I_o = 0.2\text{A}, T_J = 25^\circ\text{C}$		800		mΩ
		$V_M = 2.7\text{V}, I_o = 0.2\text{A}, T_J = 85^\circ\text{C}^1$		900		mΩ
I _{OFF}	OFF-state leakage current	$V_M = 5\text{V}$	-1		1	μA
t _{RISE}	Output rise time	$V_M = 5\text{V}, 16\Omega$ to GND, 10% to 90%V _M		70		ns
t _{FALL}	Output fall time	$V_M = 5\text{V}, 16\Omega$ to GND, 10% to 90%V _M		80		ns
T _{DEAD}	Dead time ²	$V_M = 5\text{V}$		450		ns
PWM CURRENT CONTROL (AISEN, BISEN)						
V _{TRIP}	xISEN trip voltage		160	200	240	mV
t _{OFF}	Current control constant off time	Internal PWM constant off time		23		μs
PROTECTION CIRCUITS						
I _{OC}	Overcurrent protection trip level		1.2			A
t _{DEG}	Overcurrent de-glitch time			1		μs
t _{OCR}	Overcurrent protection retry time			1.4		ms
T _{TSD} ¹	Thermal shutdown temperature		150			°C
T _{HYS}	Thermal shutdown hysteresis			20		°C

1. Not tested in production; based on design and characterization data.
2. Internal dead time. External implementation is not necessary.

6 Functional Description

6.1 Block Diagram

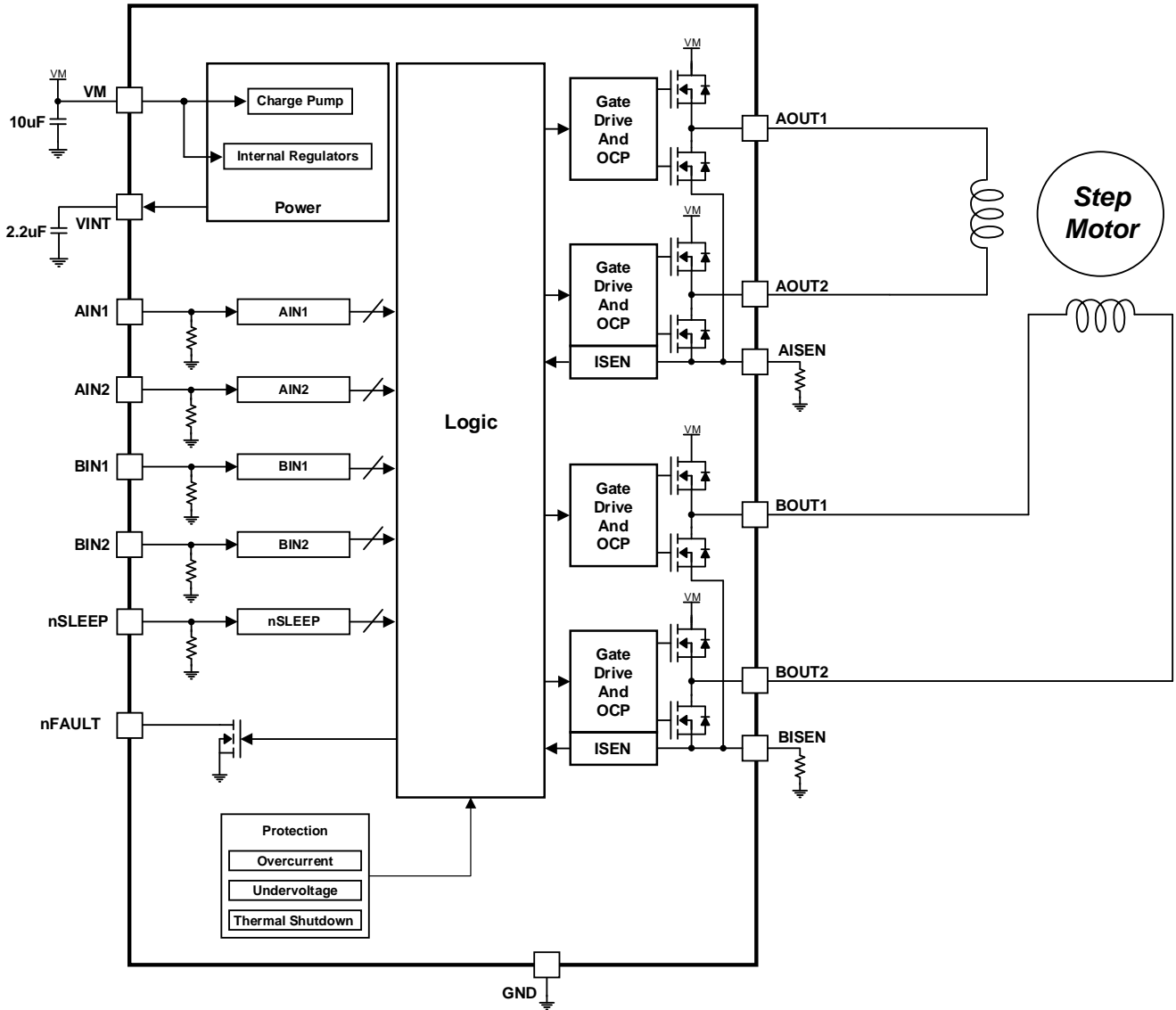

Figure 1. GD30DR3820 Functional Block Diagram

6.2 Operation

The GD30DR3820 device is an integrated motor driver solution for bipolar stepper motors. The device integrates two NMOS + NMOS H-bridges and current regulation circuitry. The GD30DR3820 can be powered with a supply voltage from 2.5V to 10.8V and can provide an output current up to 1.0A RMS.

A simple PWM interface allows easy interfacing to the controller circuit. The current regulation is a 23µs fixed off-time slow decay. The device includes a low-power sleep mode, which lets the system save power when not driving the motor.

6.2.1 PWM Motor Drivers

The GD30DR3820 contains drivers for two full H-bridges. The circuit block diagram is shown in [Figure 2](#).

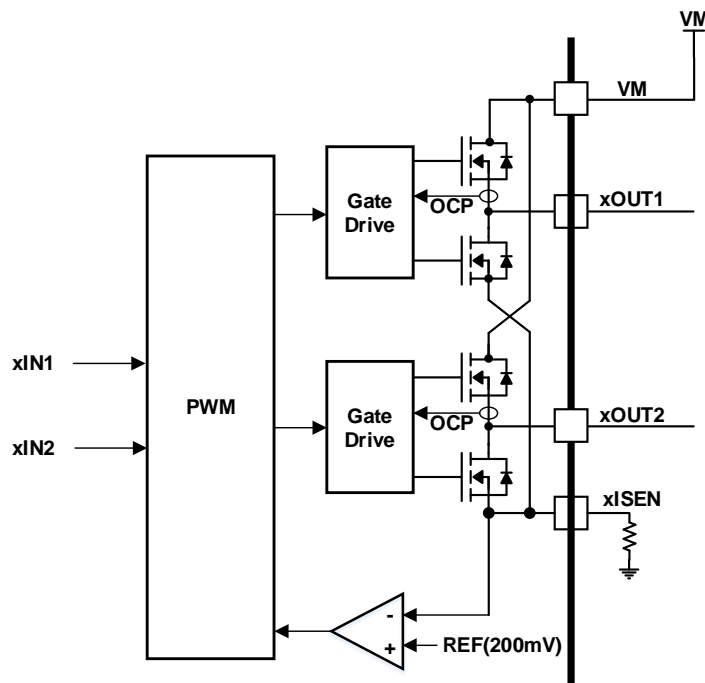

Figure 2. Motor Control Circuitry

6.2.2 Bridge Control and Decay Modes

Each H-Bridge has independent control pins and output pins, where AIN1 and AIN2 control the outputs of AOUT1 and AOUT2. Similarly, the BIN1 and BIN2 control the outputs of BOUT1 and BOUT2. The control logic is shown in [Table 1](#).

Table 1. H-Bridge Control

xIN1	xIN2	xOUT1	xOUT2	FUNCTION
0	0	Z	Z	Coast/fast decay
0	1	L	H	Reverse
1	0	H	L	Forward
1	1	L	L	Brake/slow decay

When the input signal is PWM, the speed of the motor can be justed. Since there is inductance in the motor winding, and the inductance has the characteristic that the current cannot mutate, when the drive current is interrupted, the current will find a way to continue flowing. The H-bridge provides two paths for current freewheeling. One is to disable the H-bridge and allow the current to flow through the body diode of the FET. This method is called fast decay mode. The other is to short-circuit the motor windings, which is called slow decay mode.

In summary, when one input pin is a PWM signal and the other pin is a low-level signal, it is fast decay mode. When the other pin is high-level signal, it is slow decay mode. See Table 2 for more information.

Table 2. H-Bridge PWM Control

xIN1	xIN2	FUNCTION
PWM	0	Forward PWM, fast decay
1	PWM	Forward PWM, low decay
0	PWM	Reverse PWM, fast decay
PWM	1	Reverse PWM, low decay

When disabling current control, the xISEN pin should be connected directly to ground.

Figure 3 shows the current paths in different drive and decay modes.

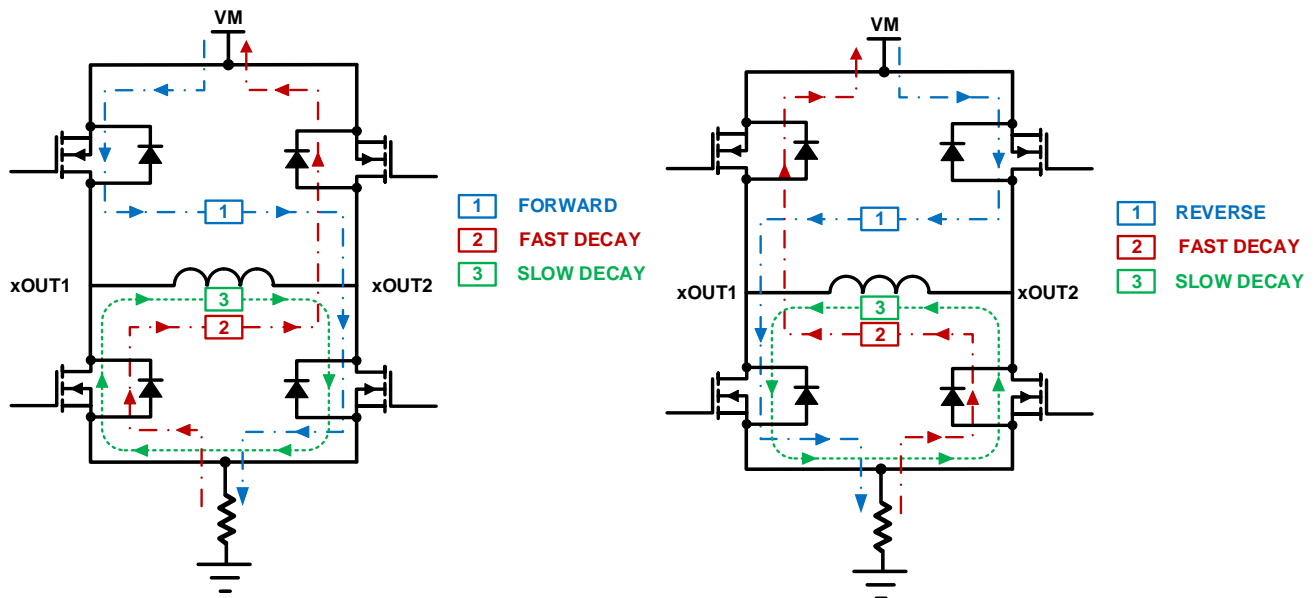

Figure 3. The driver outputs and current path

6.2.3 Current Control

The current on the motor winding can be adjusted by PWM with a certain frequency. This function can prevent excessive current from causing permanent damage to the device when the stepper motor is started or blocked.

The speed of the motor current climb depends on the voltage and winding inductance across the winding. When the device is operated with a motor, if the motor current reaches the set threshold, the H-bridge will be disabled before the next drive cycle starts. After the current is enabled, the voltage monitoring function on the xISEN pin is

enabled after a fixed blanking time.

The trip current threshold is set by a comparator that compares the voltage on the xISEN pin to an internal reference voltage(fixed at 200mv).

The tripping current is calculated as in Equation(1):

$$I_{TRIP} = \frac{200mV}{R_{xISEN}} \tag{1}$$

where: If the xISEN pin is connected to GND through a 400mΩ resistor, then the trip current will be 200mV / 400mΩ = 500mA.

NOTE: If current control is not needed, the xISEN pins should be connected directly to ground.

6.2.4 Decay Mode

When the motor current reaches the set threshold current, the H-bridge will enter the slow decay mode and re-enable the H-bridge according to the status of the input signal after a fixed period of time(23us).

6.2.5 Slow Decay

In slow-decay mode, the high-side MOSFETs are turned off, while both of the low-side MOSFETs are turned on. The motor current flowing in the two-side MOSFETs will be decreased until the fixed off time is reached (typically 23 μs). Afterwards, in order to increase the winding current again, the MOSFETs on the high-side are enabled.

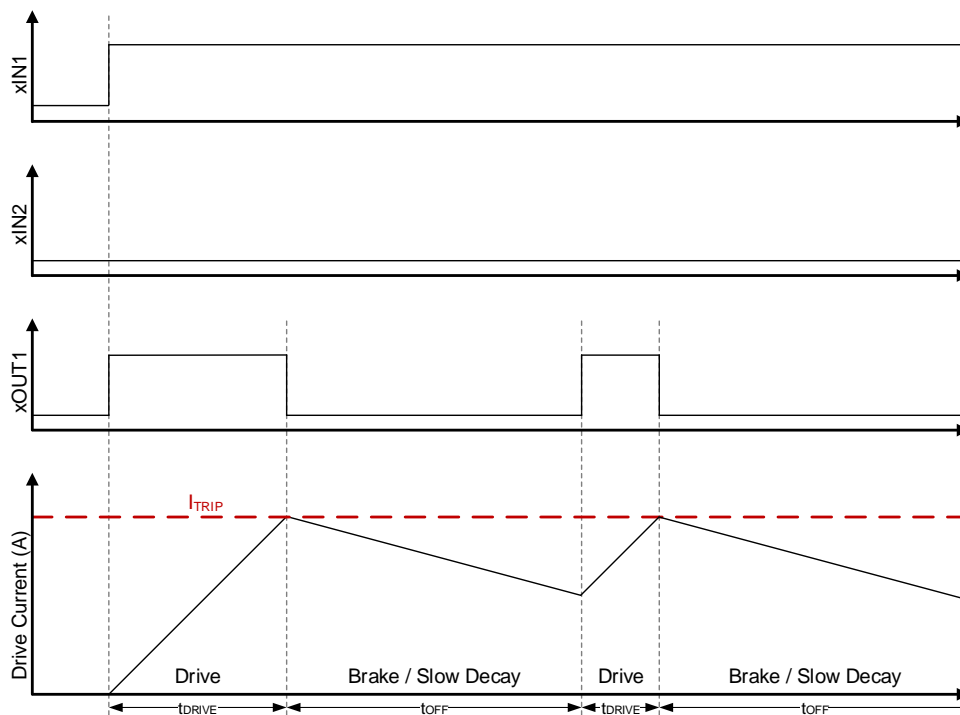

Figure 4. Slow Current Decay

6.2.6 Sleep Mode

Pulling down the nSLEEP puts the device into a low-power sleep state. In this state, the H-bridges are disabled, all internal logic is reset, all internal clocks stop working, and all inputs fail until nSLEEP is pulled up and activated. It takes some time, t_{WAKE} (typically 155us), from exit sleep mode to the motor driver becomes fully operational.

6.2.7 Protection Circuits

The GD30DR3820 is provided with overcurrent protection, overtemperature protection, and undervoltage protection functions.

6.2.7.1 VM undervoltage lockout(UVLO)

When the voltage of the VM pin is below the threshold voltage (V_{UVLO}), all circuits fail and all internal logic resets. The device returns to normal when the voltage of the VM pin rises above the threshold voltage (V_{UVLO}).

6.2.7.2 Thermal shutdown (TSD)

Once the die temperature exceeds the safe limits, all MOSFETs in the H-bridge will be disabled, and the nFAULT pin will also be driven low until the die temperature drops below the specified hysteresis (T_{HYS}). When the operation resumes, the nFAULT pin will be released.

6.2.7.3 Overcurrent protection (OCP)

Each FET has an analog current limit (I_{OCP}) circuit to limit the current through the FET, which will be realized by limiting the gate drive. All FETs in the H-bridge will be disabled and the nFAULT pin will be driven low if the analog current limiting duration exceeds the OCP deglitch time (t_{DEG}). After the OCP retry period (t_{OCP}), the driver will be re-enabled, and after the retry time, the nFAULT pin will be driven high. If the fault still exists, repeat the above operation. If the fault is eliminated, the normal operation will resum, and the nFAULT pin will remain deserted. Note that only the H-bridge that detect OCP will be disabled while other bridges work properly.

Short circuit to ground, supply, or across the motor winding will cause overcurrent shutdown, and overcurrent conditions are independently detected on both high-side and low-side devices. Please note that overcurrent protection does not use current detections circuit for PWM current control, so it can work even without xISEN resistors.

Table 3. Fault Conditions Summary

FAULT	CONDITION	ERROR REPORT	H-BRIDGE	INTERNAL CIRCUIT	RECOVERY
VM undervoltage (UVLO)	$V_M < 2.4V$	None	Disabled	Disabled	$V_M > 2.5V$
Overcurrent(OCP)	$I_{OUT} > I_{OCP}$	FAULTn	Disabled	Operating	OCP
Thermal Shutdown (TSD)	$T_J > T_{TSD}$	FAULTn	Disabled	Operating	$T_J < T_{TSD} - T_{HYS}$

6.3 Device Functional Modes

6.3.1 Device Enable

When the nSLEEP pin switches from high level to low level, after a period of time($t_{SLEEP}=10us$), GD30DR3820 will enter sleep mode, and in this mode, the H-bridge will be in a disabled state(Hi-Z).



When the nSLEEP pin switches from low level to high level, The GD30DR3820 will automatically exit the sleep mode and enter the active mode after $t_{WAKE}(155\mu s)$.

Table 4. Modes of Operation

OPERATING MODE	CONDITION	H-BRIDGE	INTERNAL CIRCUIT
Operating	nSLEEP high	Operating	Operating
Sleep mode	nSLEEP low	Disabled	Disabled
Fault encountered	Any fault condition met	Disabled	See Table 3

7 Application Information

The GD30DR3820 is typically used to drive a bipolar stepper motor.

7.1 Typical Application Circuit

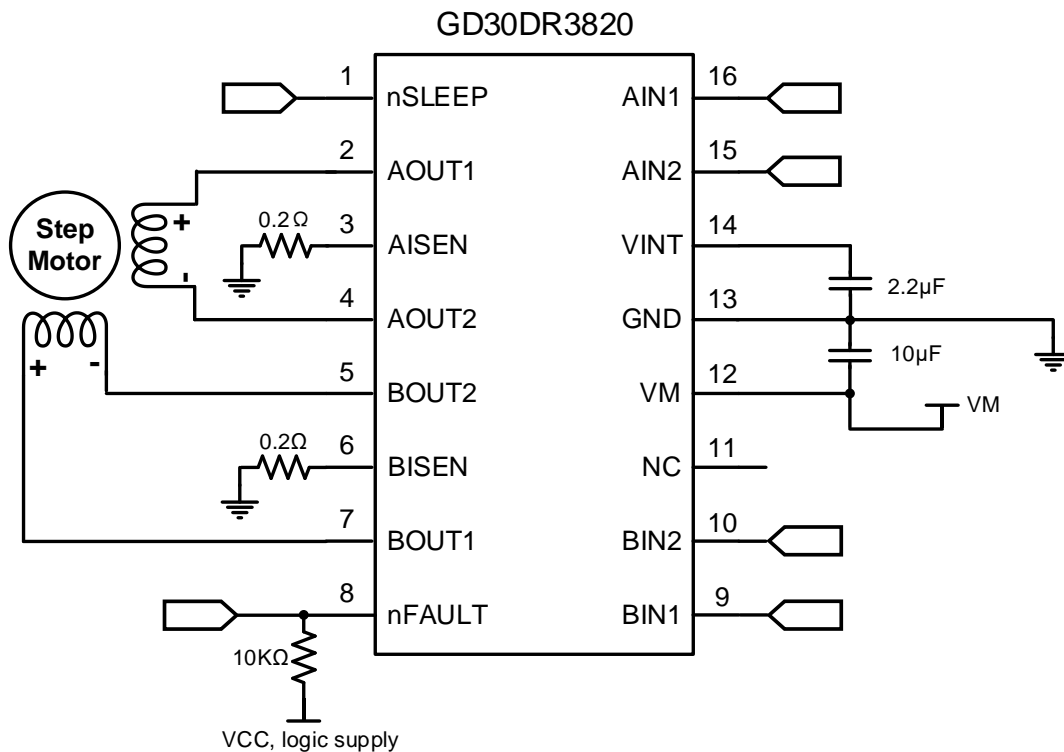

Figure 5. Schematic of GD30DR3820 Application

7.2 Design Example

For this design example, use the parameters in [Table 5](#).

Table 5. Design Parameters

PARAMETER	EXAMPLE VALUE
Motor Supply Voltage	5V
Logic Supply Voltage	3.3V
Target RMS Current	0.5A

7.3 Detailed Design Description

7.3.1 Motor Voltage

The motor voltage to use will depend on the ratings of the motor selected and the desired RPM. A higher voltage spins a bipolar stepper motor faster with the same PWM duty cycle applied to the power FETs. A higher voltage also increases the rate of current change through the inductive motor windings.

7.3.2 Motor Current Trip Point

When the voltage on pin xISEN exceeds V_{REF} (0.2V), current regulation is activated. The R_{SENSE} resistor connected from xISEN to ground, according to the [Equation\(1\)](#) to set the desired I_{TRIP} level.

7.3.3 Sense Resistor

To ensure optimal performance, it is important for the sense resistor to be:

- Surface-mount
- Rated power meets the requirements
- Low Inductance
- Placed as close as to the motor driver pin

The power dissipated by the sense resistor can be calculated using $(I_{RMS})^2 \times R$. For example, if peak motor current is 0.8A, RMS motor current is 0.5A, and a 0.2Ω sense resistor is used, the resistor dissipates $0.5A^2 \times 0.2\Omega = 0.05W$. The power rapidly increases with higher current levels.

Resistors generally have a rated power within a specific range of ambient temperature and a reduced power curve at high ambient temperatures. When the PCB is shared with other components generating heat, the system designer should increase the margin. It is always best to measure the actual sense resistor temperature in a final system.

Power resistors are larger and more expensive than standard resistors, and it is common to use multiple standard resistors in parallel between the sense node and ground to distribute the current and heat dissipation.

7.4 Power Dissipation

Power dissipation in the GD30DR3820 is dominated by the power dissipated in the output FET resistance, or $R_{DS(ON)}$. The DC power dissipation of one H-bridge can be roughly estimated by [Equation\(2\)](#).

$$P_D \approx I_{RMS}^2 \times (R_{HS_DS(ON)} + R_{LS_DS(ON)}) \quad (2)$$

where

- P_D is the device power dissipation
- $R_{HS_DS(ON)}$ is the resistance of the high-side FET
- $R_{LS_DS(ON)}$ is the resistance of the low-side FET
- I_{RMS} is the RMS or DC output current being supplied to the load

The maximum amount of power that can be dissipated in the device is dependent on ambient temperature and heatsinking.

$R_{DS(ON)}$ increases with temperature, so as the device heats, the power dissipation increases. This must be taken into consideration when sizing the heatsink.

7.5 Typical Application Curves

T_A = 25°C, unless otherwise noted.

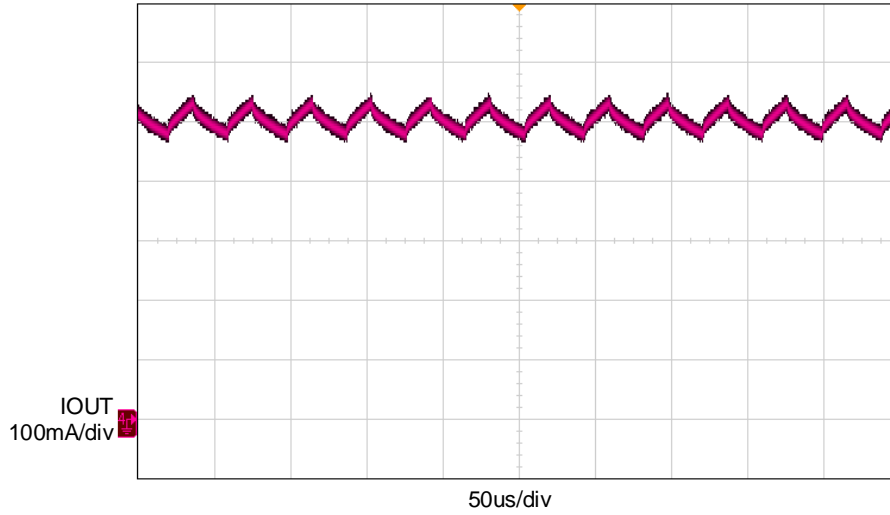

Figure 6. Current Regulation

8 Layout Guidelines and Example

8.1 Layout Guidelines

Low ESR ceramic capacitors should be utilized for the VM to GND bypass capacitors. 10uF X5R or X7R types are recommended. These capacitors should be placed as close to the VM pins as possible with a thick trace or ground plane connection to the device GND pin.

In addition, bulk capacitor is required on the VM pin. This bulk capacitor can be ceramic or electrolytic type, but should also be placed as close as possible to the VM pin to minimize the loop inductance.

The high-current device outputs should use wide metal trace, and numerous vias should be used when connecting PCB layers.

Bypass VINT to ground with a 2.2uF ceramic capacitor rated 6.3V. Place this bypass capacitor as close to the pin as possible.

8.2 Layout Example

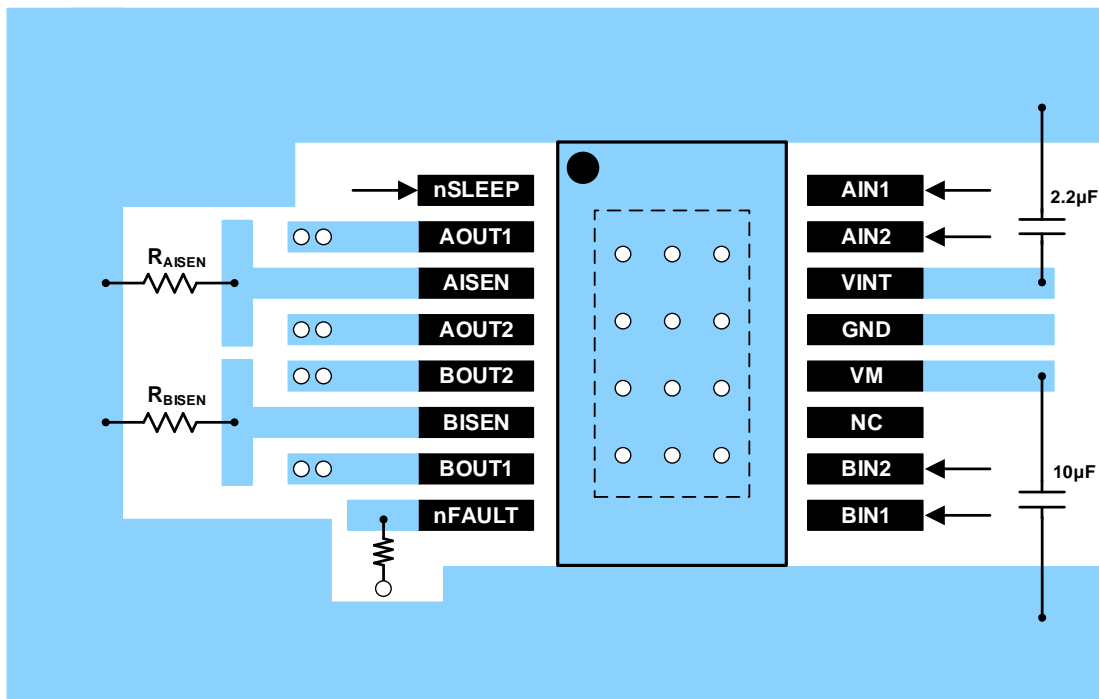
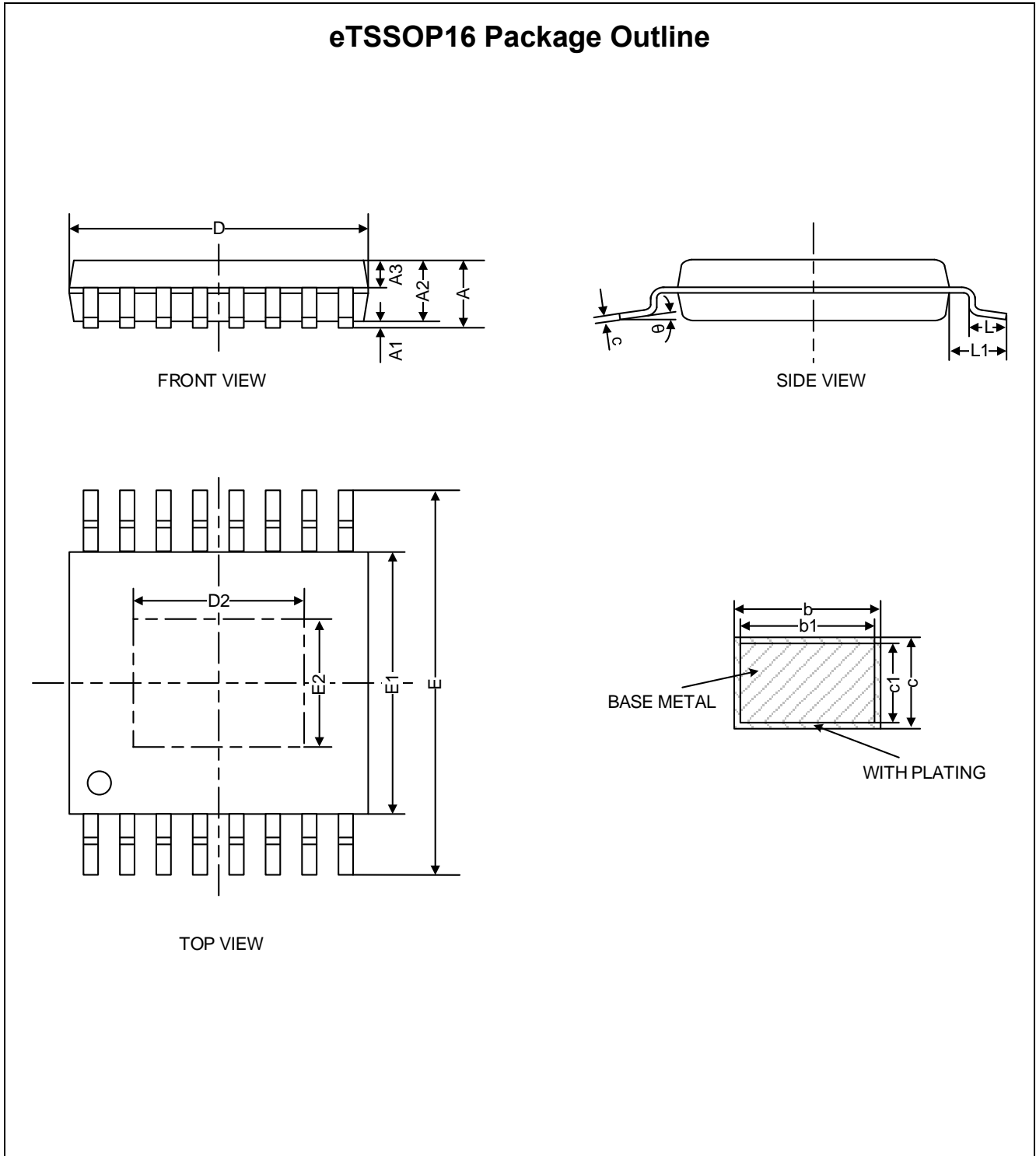

Figure 7. Typical Layout Example

9 Package Information

9.1 Outline Dimensions



NOTES:

1. All dimensions are in millimeters.
2. Package dimensions does not include mold flash, protrusions, or gate burrs.
3. Refer to the [Table 6 eTSSOP16 dimensions\(mm\)](#).

Table 6. eTSSOP16 dimensions(mm)

SYMBOL	MIN	TYP	MAX
A			1.2
A1	0.05		0.15
A2	0.90	1.00	1.05
A3	0.39	0.44	0.49
b	0.20		0.28
b1	0.19	0.22	0.25
c	0.13		0.17
c1	0.12	0.13	0.14
D	4.90	5.00	5.10
E	6.20	6.40	6.60
E1	4.30	4.40	4.50
e	0.65 BSC		
L	0.45		0.75
L1	1.00 BSC		
θ	0°		8°
D2	2.80 REF (L/F Size = 91 * 118)		
E2	2.10 REF (L/F Size = 91 * 118)		

QFN16 Package Outline

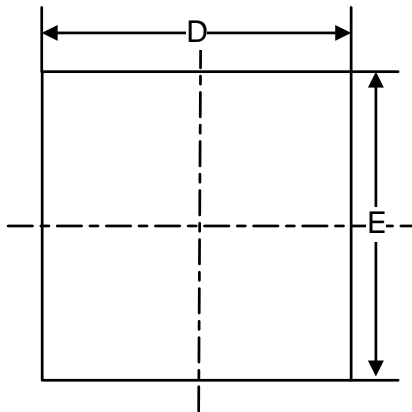

TOP VIEW

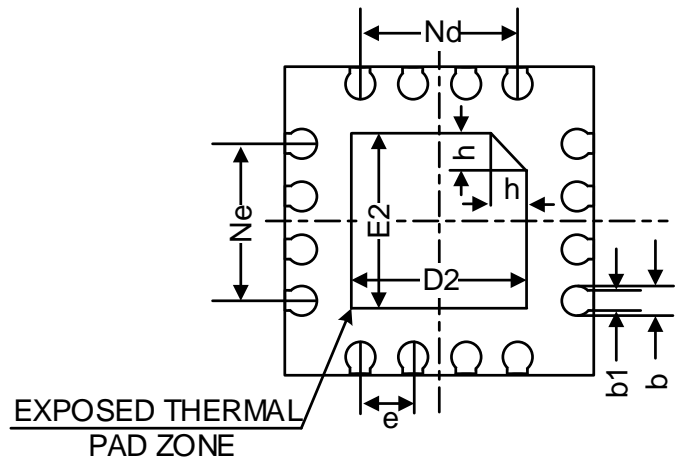

BOTTOM VIEW

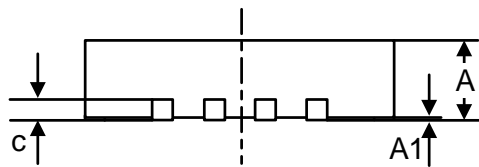

FRONT VIEW

NOTES: (continued)

1. Refer to the [Table 7 QFN16 dimensions\(mm\)](#).

Table 7. QFN16 dimensions(mm)

SYMBOL	MIN	TYP	MAX
A	0.70	0.75	0.80
A1	0	0.02	0.05
b	0.18	0.25	0.30
b1	0.18 REF		
c	0.18 REF		
D	2.90	3.00	3.10
D2	1.60	1.70	1.80
e	0.50 BSC		
Ne	1.50 BSC		
Nd	1.50 BSC		
E	2.90	3.00	3.10
E2	1.60	1.70	1.80
L	0.25	0.30	0.35
h	0.30	0.35	0.40

9.2 Recommended Land Pattern

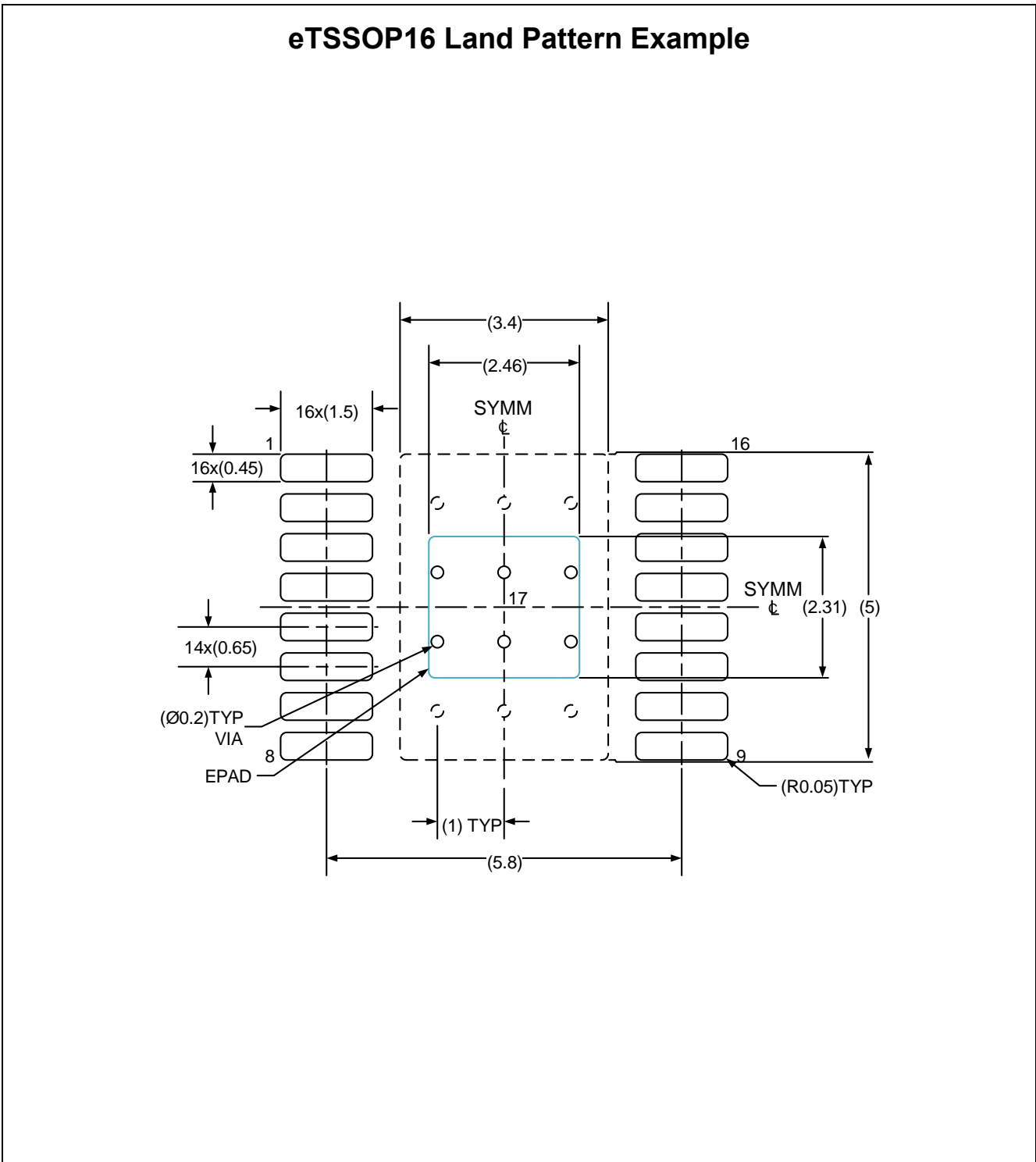

NOTES: (continued)

1. Refer to the IPC-7351 can also help you complete the designs.
2. Exposed metal shown.
3. Drawing is 10X scale.

QFN16 Land Pattern Example

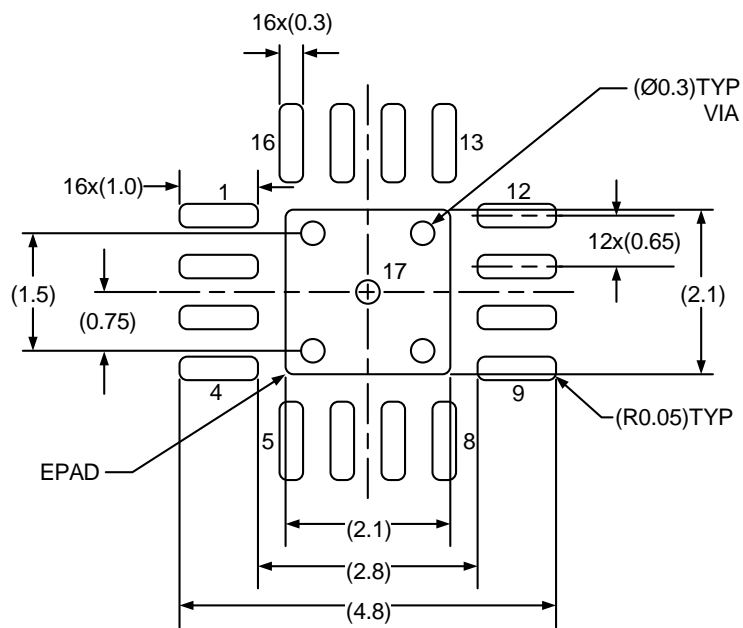

NOTES: (continued)

1. Refer to the IPC-7351 can also help you complete the designs.
2. Exposed metal shown.
3. Drawing is 10X scale.



10 Ordering Information

Ordering Code	Package Type	ECO Plan	Packing Type	MOQ	OP Temp(°C)
GD30DR3820LPTR-K	eTSSOP16	Green	Tape & Reel	3000	Industrial -40°C to +85°C
GD30DR3820LUTR-K	QFN16	Green	Tape & Reel	3000	Industrial -40°C to +85°C

Important Notice

This document is the property of GigaDevice Semiconductor Inc. and its subsidiaries (the "Company"). This document, including any product of the Company described in this document (the "Product"), is owned by the Company according to the laws of the People's Republic of China and other applicable laws. The Company reserves all rights under such laws and no Intellectual Property Rights are transferred (either wholly or partially) or licensed by the Company (either expressly or impliedly) herein. The names and brands of third party referred thereto (if any) are the property of their respective owner and referred to for identification purposes only.

The Company makes no representations or warranties of any kind, express or implied, with regard to the merchantability and the fitness for a particular purpose of the Product, nor does the Company assume any liability arising out of the application or use of any Product described in this document. Any information provided in this document is provided only for reference purposes. It is the sole responsibility of the user of this document to determine whether the Product is suitable and fit for its applications and products planned, and properly design, program, and test the functionality and safety of its applications and products planned using the Product. Unless otherwise expressly specified in the datasheet of the Product, the Product is designed, developed, and/or manufactured for ordinary business, industrial, personal, and/or household applications only, and the Product is not designed or intended for use in (i) safety critical applications such as weapons systems, nuclear facilities, atomic energy controller, combustion controller, aeronautic or aerospace applications, traffic signal instruments, pollution control or hazardous substance management; (ii) life-support systems, other medical equipment or systems (including life support equipment and surgical implants); (iii) automotive applications or environments, including but not limited to applications for active and passive safety of automobiles (regardless of front market or aftermarket), for example, EPS, braking, ADAS (camera/fusion), EMS, TCU, BMS, BSG, TPMS, Airbag, Suspension, DMS, ICMS, Domain, ESC, DCDC, e-clutch, advanced-lighting, etc.. Automobile herein means a vehicle propelled by a self-contained motor, engine or the like, such as, without limitation, cars, trucks, motorcycles, electric cars, and other transportation devices; and/or (iv) other uses where the failure of the device or the Product can reasonably be expected to result in personal injury, death, or severe property or environmental damage (collectively "Unintended Uses"). Customers shall take any and all actions to ensure the Product meets the applicable laws and regulations. The Company is not liable for, in whole or in part, and customers shall hereby release the Company as well as its suppliers and/or distributors from, any claim, damage, or other liability arising from or related to all Unintended Uses of the Product. Customers shall indemnify and hold the Company, and its officers, employees, subsidiaries, affiliates as well as its suppliers and/or distributors harmless from and against all claims, costs, damages, and other liabilities, including claims for personal injury or death, arising from or related to any Unintended Uses of the Product.

Information in this document is provided solely in connection with the Product. The Company reserves the right to make changes, corrections, modifications or improvements to this document and the Product described herein at any time without notice. The Company shall have no responsibility whatsoever for conflicts or incompatibilities arising from future changes to them. Information in this document supersedes and replaces information previously supplied in any prior versions of this document.

© 2023 GigaDevice – All rights reserved